



fantech[®]
a systemair company

Installation, Operation and Maintenance Instructions

EN

PBF

Premium Bath Fans

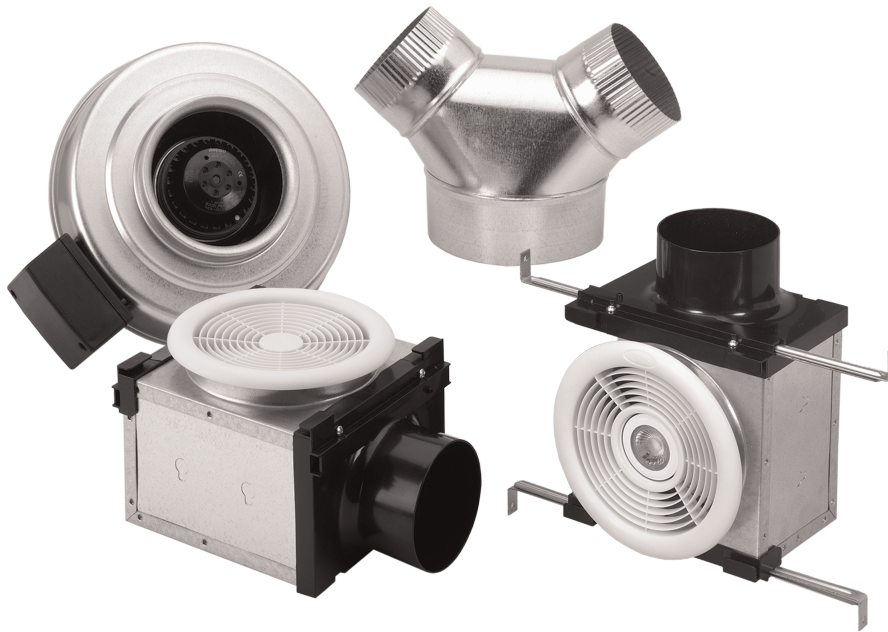

Table of contents

| | | |
|--------|-----------------------------------------------------|----|
| 1 | Introduction | 1 |
| 1.1 | Product Description..... | 1 |
| 1.2 | Intended Use | 1 |
| 1.3 | Document Description | 1 |
| 1.4 | Fantech Warranty | 1 |
| 1.5 | Product Overview | 2 |
| 1.6 | Nameplate | 5 |
| 1.6.1 | Type Designation | 5 |
| 2 | Safety | 6 |
| 2.1 | Safety definitions..... | 6 |
| 2.2 | Safety Instructions | 6 |
| 2.3 | Personal protective equipment | 6 |
| 3 | Installation..... | 7 |
| 3.1 | To Do Before the Installation of the Product | 7 |
| 3.2 | To Install the Product..... | 7 |
| 3.3 | To Install the Ceiling Canisters..... | 9 |
| 3.4 | To Do Before the Installation of the Duct Run | 10 |
| 3.5 | To Attach the Duct without Mounting Clamps | 11 |
| 3.6 | To Attach the Duct | 11 |
| 3.7 | To Manage the Duct Run..... | 11 |
| 4 | Electrical connection..... | 12 |
| 4.1 | To connect the product to the power supply | 12 |
| 4.2 | Speed controller for AC motors..... | 12 |
| 4.3 | Motor Protection..... | 12 |
| 5 | Operation..... | 12 |
| 5.1 | To Start the Product with an AC Motor..... | 12 |
| 5.2 | To Start the Product with an EC Motor..... | 12 |
| 5.2.1 | To Stop the Product | 12 |
| 6 | Commissioning | 13 |
| 6.1 | To Do Before the Commissioning | 13 |
| 6.2 | To Do the Commissioning..... | 13 |
| 7 | Maintenance..... | 14 |
| 7.1 | Maintenance Schedule | 14 |
| 7.2 | Spare Parts | 14 |
| 7.3 | To clean the product..... | 15 |
| 8 | Troubleshooting..... | 16 |
| 9 | Disposal | 17 |
| 10 | Technical data | 18 |
| 10.1 | Technical Data Overview..... | 18 |
| 10.2 | Wiring Diagram Overview..... | 18 |
| 10.2.1 | Wiring Diagrams for AC Fans | 19 |
| 10.3 | Product Dimensions..... | 22 |

1 Introduction

1.1 Product Description

This product is a circular duct fan with an airtight casing made from sheet metal.

Other components, such as wyers, ceiling canisters, LED lights, and more, are also included.

The product is not supplied with a wall switch or FC mounting clamps, these parts are available and recommended as accessories.

Damp location rated.

1.2 Intended Use

This product is intended for general ventilation use only.

This product is used for the transportation of clean or contaminated air with a maximum temperature of 140°F and 95% air humidity.

The product should not be used for the transportation of air that contains explosive, flammable or aggressive media. The product is not designed for locations where there is a risk of explosion.

The product is intended for installation in indoor environments and wet rooms. It is also possible to install the product in outdoor environments with weather protection. The product operates within ambient temperatures of -13°F to 140°F.

1.3 Document Description

This document contains instructions for installation, operation and maintenance of the product. The procedures must be done by approved personnel only.

Speak to Fantech for more information on how to install the product in different installation locations.

1.4 Fantech Warranty



Make a scan of the code above to access Fantech's warranty in English, French, or Spanish. This product has a 7 year warranty.

If additional support is needed to retrieve the warranty, visit fantech.net; call (800) 747-1762 (US), (800) 565-3548 (Canada), or +52 55 1328-7328 (Latin America); email support@fantech.net; or mail us at 10048 Industrial Blvd, Lenexa, KS 66215 United States or at 50 Kanalfläkt Way, Bouctouche, NB E4S 3M5 Canada.

1.5 Product Overview

For products:

- PB 110, #40568

- PB 110 L7, #44942
- PB 110 L10, #44943
- PB 190, #40571

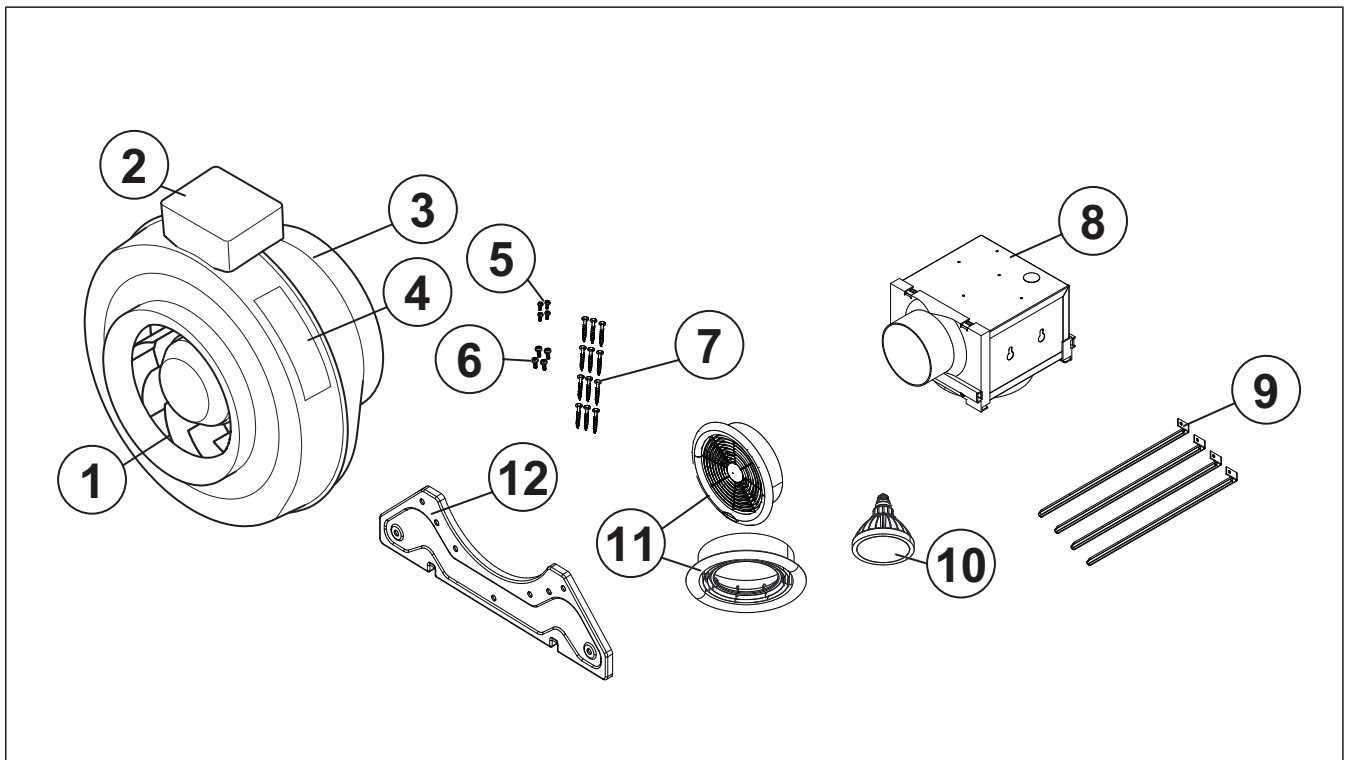

1. Impeller
2. Electrical box
3. Casing
4. Name plate
5. Anti-slide Screws, quantity 4
6. Sheet-metal screws, quantity 4
7. Wood screws, quantity 12
8. Ceiling canister, quantity 1
9. Hanger bars, quantity 4
10. LED lamp, quantity 1
- On applicable products only
11. Ceiling grille, quantity 1
12. Mounting bracket, quantity 1

For products:

- PB 270-2, #40572
- PB 270L7V2, #44946
- PB 270L7-2, #44944

- PB 270L10V2, #44947
- PB 270L710-2, #44948
- PB 270L10-2, #44945

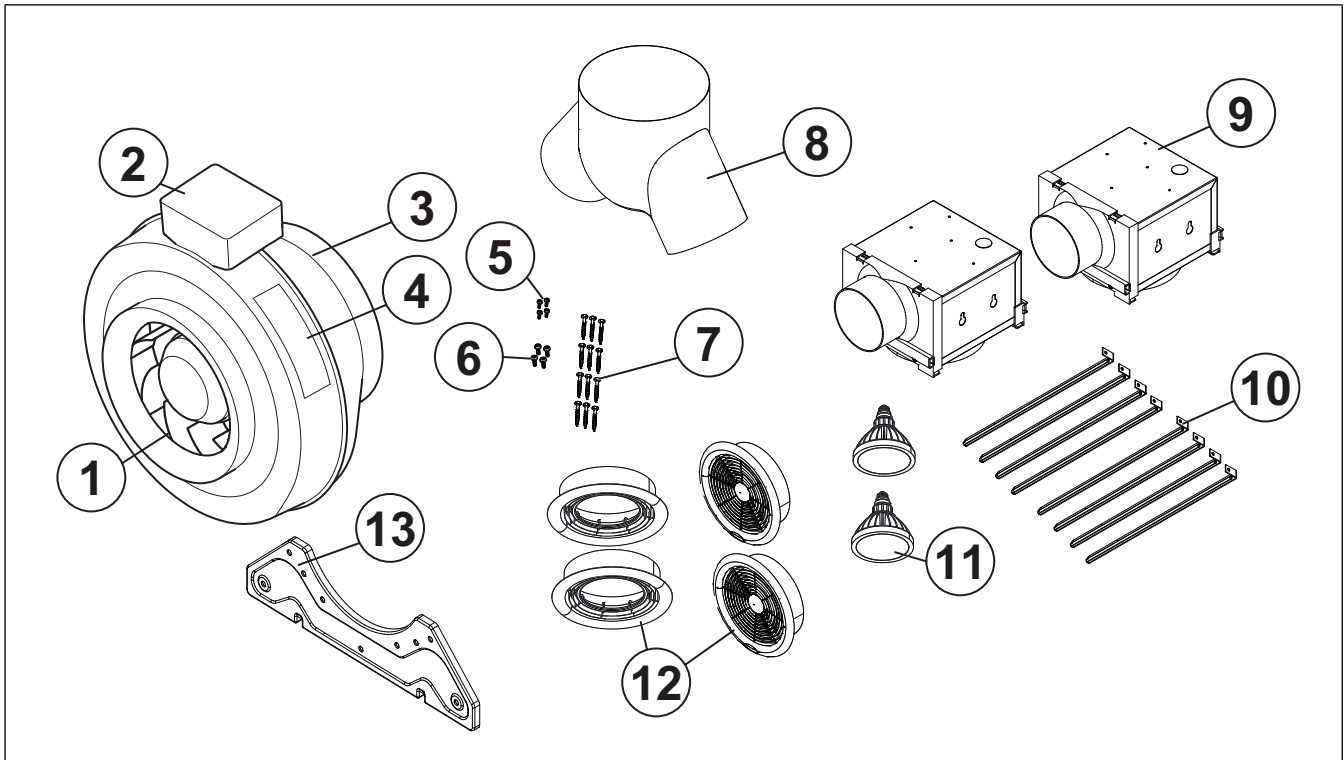

- | | |
|-----------------------------------|------------------------------------------------------|
| 1. Impeller | 9. Ceiling canister, quantity 2 |
| 2. Electrical box | 10. Hanger bars, quantity 8 |
| 3. Casing | 11. LED lamp, quantity differs between product types |
| 4. Name plate | On applicable products only |
| 5. Anti-slide Screws, quantity 4 | 12. Ceiling grille, quantity 2 |
| 6. Sheet-metal screws, quantity 4 | 13. Mounting bracket, quantity 1 |
| 7. Wood screws, quantity 12 | |
| 8. Wye, quantity 1 | |

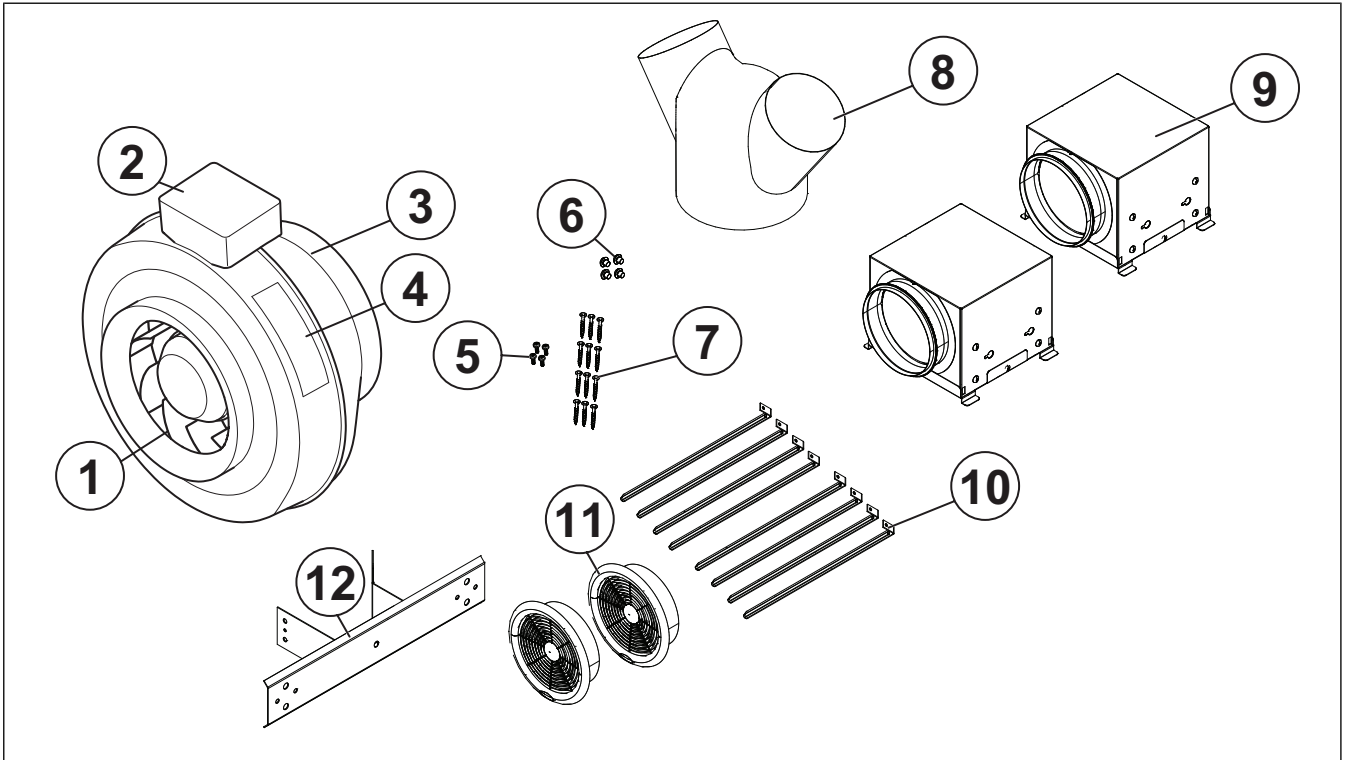

- | | |
|-----------------------------------|----------------------------------|
| 1. Impeller | 7. Wood screws, quantity 12 |
| 2. Electrical box | 8. Wye, quantity 1 |
| 3. Casing | 9. Ceiling canister, quantity 2 |
| 4. Name plate | 10. Hanger bars, quantity 8 |
| 5. Sheet-metal screws, quantity 4 | 11. Ceiling grille, quantity 2 |
| 6. Rubber Bumpers, quantity 4 | 12. Mounting bracket, quantity 1 |

1.6 Nameplate

Note:

Make sure the voltage at the fan agrees with the motor name plate.

Note:

This is the general nameplate used on all Fantech products, some elements might not be applicable to your specified product.

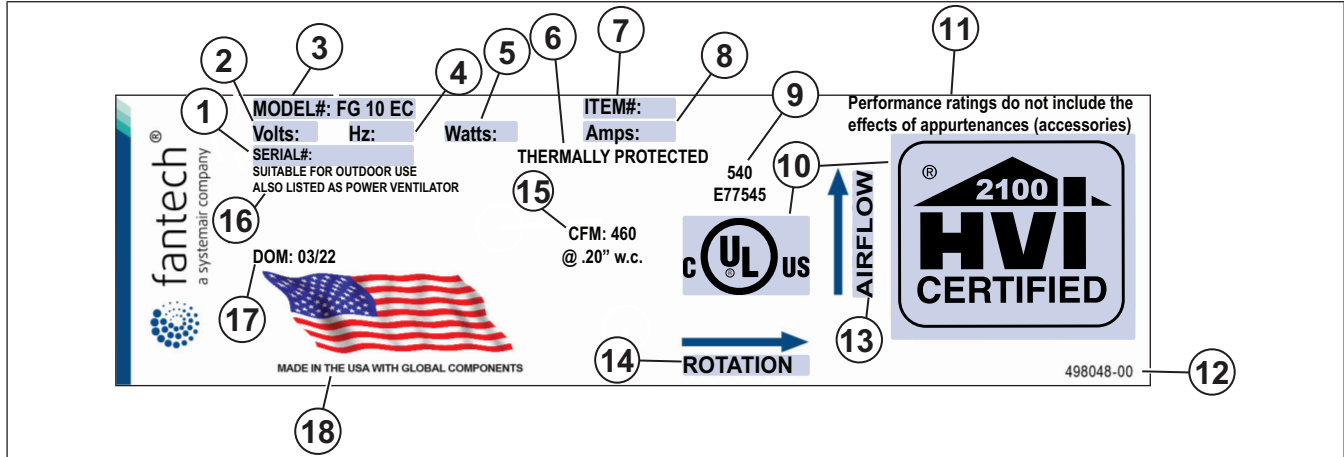

- | | |
|-----------------------------------------------------------------------------------------------|-----------------------------------------------------|
| 1. Serial Number | 10. Certifications |
| 2. Voltage, Volt | 11. Disclaimer |
| 3. Type Designation: Product Name, Dimension, and Motor Type. Refer to 1.6.1 Type Designation | 12. Item Number for Nameplate |
| 4. Frequency, Hertz | 13. Direction of Airflow |
| 5. Input Power, Watt | 14. Direction of Rotation |
| 6. Motor Protection | 15. Cubic Feet per Minute at Inches of Water Column |
| 7. Item Number | 16. Acceptable Uses & Alternate Names |
| 8. Current, Ampere | 17. Date of manufacture (MM/YY) |
| 9. Factory Location & Certification File Number | 18. Country of Origin |

1.6.1 Type Designation

| | | |
|---------------------------------------------------|-------------------------------------------------------------------------------------------------------------------------------|--------------------------------------------------------------------------------------------------------------------------------------------------------------------------------------------------------------------------------------------------------------------------------------|
| Product Name | <ul style="list-style-type: none"> • PB 110, #40568 • PB 110 L7, #44942 • PB 110 L10, #44943 | <ul style="list-style-type: none"> • PB 190, #40571 • PB 270-2, #40572 • PB 270L7V2, #44946 • PB 270L7-2, #44944 • PB 270L10V2, #44947 • PB 270L710-2, #44948 • PB 270L10-2, #44945 • PB 370-2, #45433 |
| Duct Connection Dimensions in inches (mm.) | 4 (102) | 6 (152) |
| Motor Type | AC: Alternating Current, 1-phase | |

2 Safety

2.1 Safety definitions

Warnings, cautions and notes are used to point out specially important parts of the manual.



Warning

If you do not obey these instructions, there is a risk of death or injury.



Caution

If you do not obey these instructions, there is a risk of damage to the product, other materials or the adjacent area.

Note:

Information that is necessary in a given situation.

2.2 Safety Instructions



Warning

TO REDUCE THE RISK OF FIRE, ELECTRIC SHOCK, OR INJURY TO PERSONS - OBSERVE THE FOLLOWING:

- Use this unit only in the manner intended by the manufacturer. If you have any questions, contact your manufacturer's representative.
- Before servicing or cleaning unit, switch power off at service panel and lock the service disconnecting means to prevent power from being switched on accidentally. When the service disconnecting means cannot be locked, securely fasten a prominent warning device, such as a tag, to the service panel.
- Installation work and electrical wiring must be done by qualified person(s) in accordance with all applicable codes and standards, including fire-rated construction.
- Sufficient air is needed for proper combustion and exhausting of gases through the flue (chimney) of fuel burning equipment to prevent back drafting. Follow the heating equipment manufacturer's guideline and safety standards such as those published by the National Fire Protection Association (NFPA), and the American Society for Heating, Refrigeration and Air Conditioning Engineers (ASHRAE), and the local code authorities.
- When cutting or drilling into wall and ceiling, do not damage electrical wiring and other hidden utilities.
- Ducted exhaust fans must always be vented to the outdoors.
- If this unit is to be installed over a tub or shower, it must be marked as appropriate for the application and be connected to a GFCI (Ground Fault Circuit Interrupter) – protected branch circuit.
- Never place a switch where it can be reached from a tub or shower.
- TO REDUCE THE RISK OF FIRE, USE ONLY METAL DUCTWORK.



Caution

To decrease the risk of product malfunction or damage to the product or surrounding finishes and walls, read and obey the caution instructions that follow before you do work on the product:

- For General Ventilating Use Only. Do Not Use To Exhaust Hazardous Or Explosive Material and Vapors.
- Examine the packaging for transportation damage and remove the packaging from the product carefully. Do this within 15 days after receipt. If damaged, tell the carrier about the damage. Do not operate this product if there is visible damage to the blower or impeller assembly.
- This fan shall not be installed behind a suspended floor/ceiling or a structural wall, ceiling, or floor.
- Install screen guards within 7 feet (2.1 meters) of working area of the product.
- Do not clean the product with chemicals that can cause corrosion or water hotter than 140° Fahrenheit (60° Celsius).
- Do not block the air intakes or exhaust.
- Do not release air into spaces within walls or into attics, crawl spaces, or garages.

Note:

Ducting has a strong effect on the air flow, noise and energy use of the fan. Use the shortest, straightest duct routing possible for best performance, and avoid installing the fan with smaller ducts than recommended. Insulation around the ducts can reduce energy loss and inhibit mold growth. Fans installed with existing ducts may not achieve their rated air flow.

2.3 Personal protective equipment

Use personal protective equipment during all work on the product.

- Approved eye protection
- Approved protective helmet
- Approved hearing protection
- Approved protective gloves
- Approved protective shoes
- Approved work clothing

3 Installation

3.1 To Do Before the Installation of the Product

Note:

Do not install the product with the electrical box down as moisture can collect in the electrical cover.

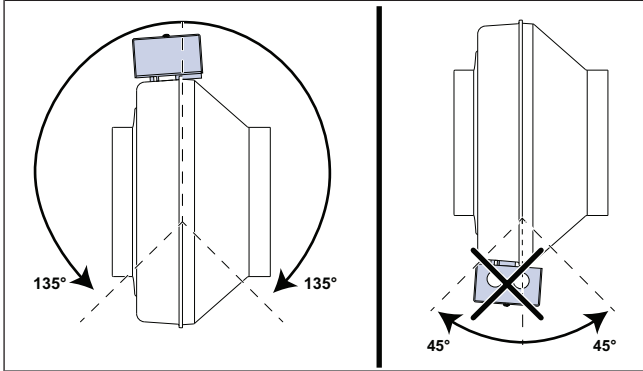

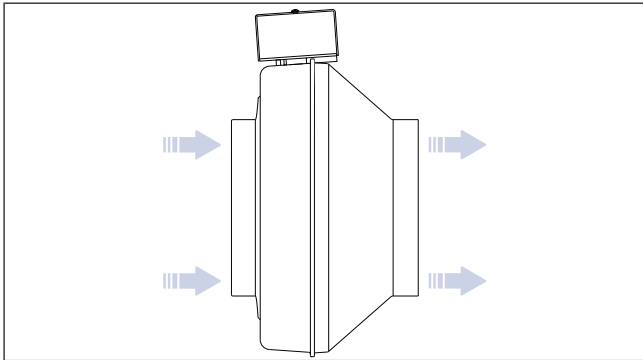

Note:

Install the product correctly in relation to the airflow.



3.2 To Install the Product

Caution

 If you use the wrong length screws it will damage the motor impeller.

Caution

 If you mount the product in a horizontal position, make sure the electrical box is not pointed down.

Note:

To install the product in a vertical position, use the two middle slots.

To install the product in a horizontal position, use the two outer slots instead of the two middle slots.

Note:

For products:

- PB 110, #40568
- PB 110 L7, #44942
- PB 110 L10, #44943
- PB 190, #40571

- 1 Choose a location 8 ft. (2.4 m.) from the location of the intake grille and a location where servicing the fan product is easy. Put the product here.
- 2 Where the product will be attached, make a mark through the applicable holes of the bracket onto the support beam.
- 3 With a 13/64 in. (5 mm.) drill bit and drill, use the marks for guidance and make the necessary quantity of pilot holes in the support beam.
- 4 Install the necessary quantity of 3/4 in. (19 mm.) wood screws into the support beam. Keep sufficient space between the beam and the screw head for the bracket.
- 5 On the opposite end of the electrical box, position the bracket onto the product.
- 6 With a 3/32 in. (2 mm.) drill bit and a drill, use the marks for guidance and make the necessary quantity of pilot holes in the product.
- 7 Use the necessary quantity of sheet-metal 1/2 in. (13 mm.) screws to attach the mounting bracket to the product.
- 8 Attach the mounting bracket onto the installed wood screws and safety the wood screws to the beam.

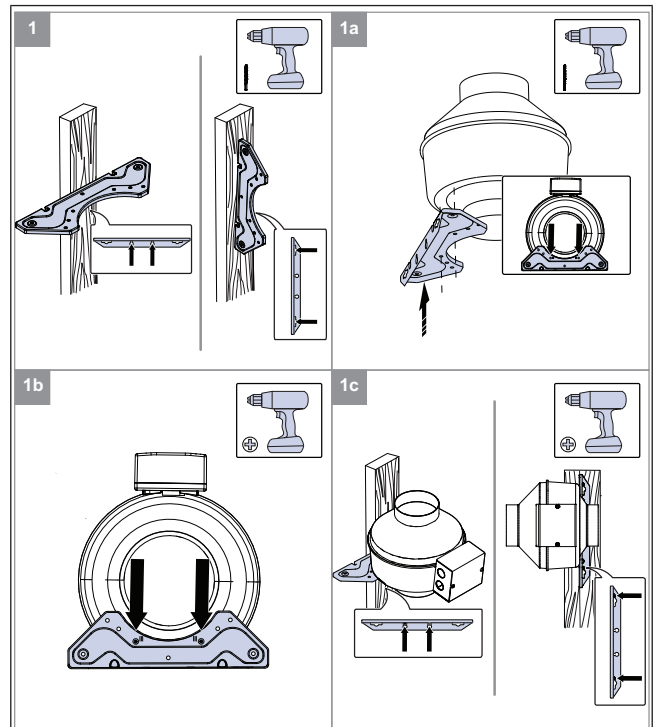

Note:

For products:

- PB 270-2, #40572
- PB 270L7V2, #44946
- PB 270L7-2, #44944
- PB 270L10V2, #44947
- PB 270L710-2, #44948
- PB 270L10-2, #44945

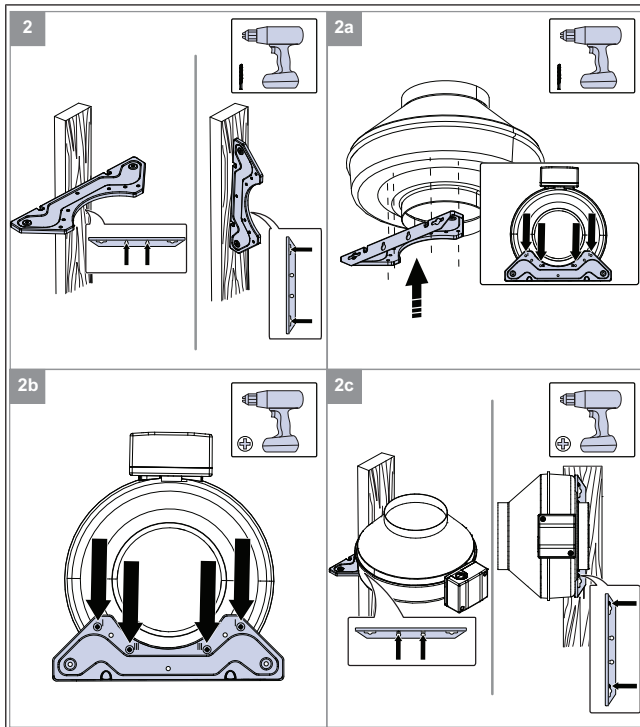

Note:

For products:

- PB 370-2, #45433

- 1 Attach the rubber bumpers to the bracket as shown in the graphic from this section.
This step is optional.
- 2 Where the product will be attached, make a mark through the applicable holes of the bracket onto the support beam.
- 3 With a 13/64 in. (5 mm.) drill bit and drill, use the marks for guidance and make the necessary quantity of pilot holes in the support beam.
- 4 On the opposite end of the electrical box, position the bracket onto the product.
- 5 Make a mark through the applicable holes of the bracket onto the product.
- 6 With a 3/32 in. (2 mm.) drill bit and a drill, use the marks for guidance and make the necessary quantity of pilot holes in the product.
- 7 Use the necessary quantity of sheet-metal 1/2 in. (13 mm.) screws to attach the mounting bracket to the product.
- 8 Use the necessary amount of supplied wood screws to install the product assembly to the support beam.

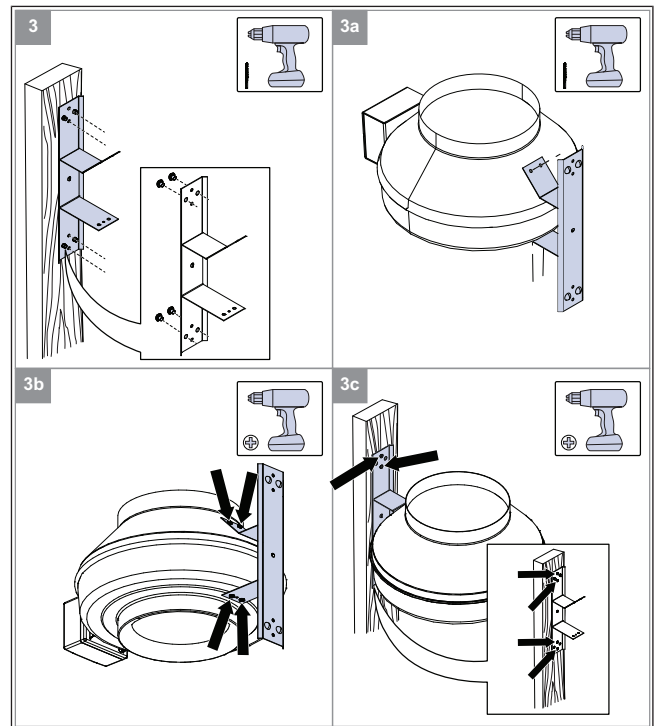

To Install the Product with Steel Wire and FC Mounting Clamps

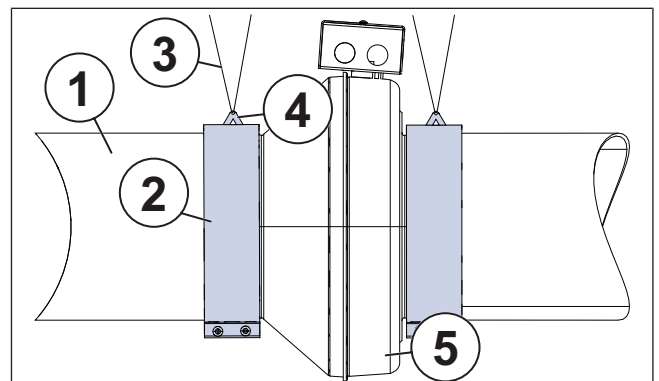

1. Duct
2. FC Mounting Clamp
3. Steel Wire
4. Hanging Tab
5. PB Series Fan

3.3 To Install the Ceiling Canisters

To Install the Canister with Hanger Brackets (New Construction)

| Maximum Installation Range between Ceiling Joists (on Center) | | |
|---------------------------------------------------------------|-----------------|-----------------|
| Duct Connection Dimensions in inches (mm.) Canister Type | 4 in. (102 mm.) | 6 in. (152 mm.) |
| Distance | 24 (610) | 16 (406) |

| Hanger Bar Position (A) | | |
|-------------------------------------------------------------|------------------|--------------------|
| Duct Connection Dimensions in inches (mm.) Canister Type | 4 in. (102 mm.) | 6 in. (152 mm.) |
| Distance from Bottom Edge of Ceiling Joist | 3/16 in. (5 mm.) | 15/32 in. (12 mm.) |

- 1 If drywall or ceiling material is thicker than 5/8 in. (16 mm.), remove the locator tabs to allow the grille collar to be flush with the finished ceiling material.
- 2 Put the hanger bars in position. Refer to the tables within this section.
- 3 Make marks where the hanger bars will be put.
- 4 Refer to the marks and use four (4) supplied wood screws (B) to install the hanger bars to the joists.
- 5 Use two (2) supplied anti-slide screws (C) on both sides of the canister to lock the hanger bars in position.

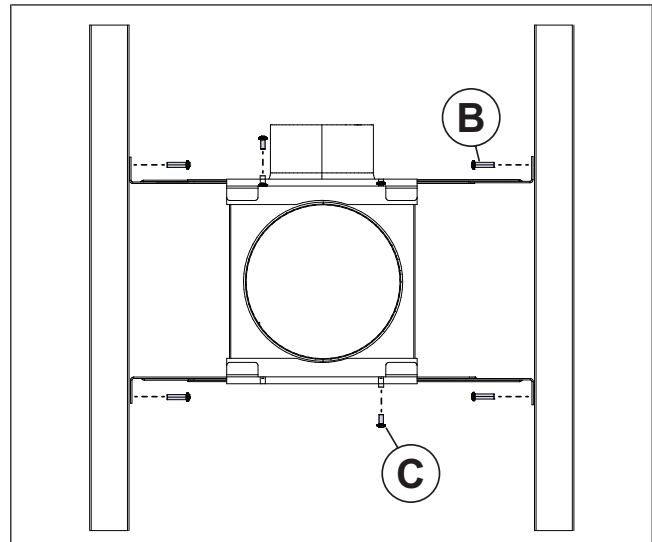
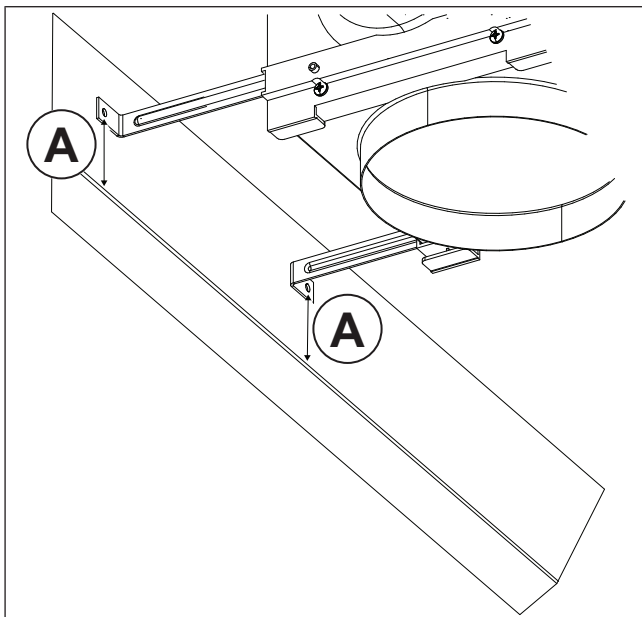

- 6 When ceiling material is installed, cut a 6 in. (152 mm.) hole for the ceiling grille.

To Install the Canister to the Ceiling Joists (New Construction)

- 1 Align the canister locator tabs (A) with the bottom edge of the ceiling joist.

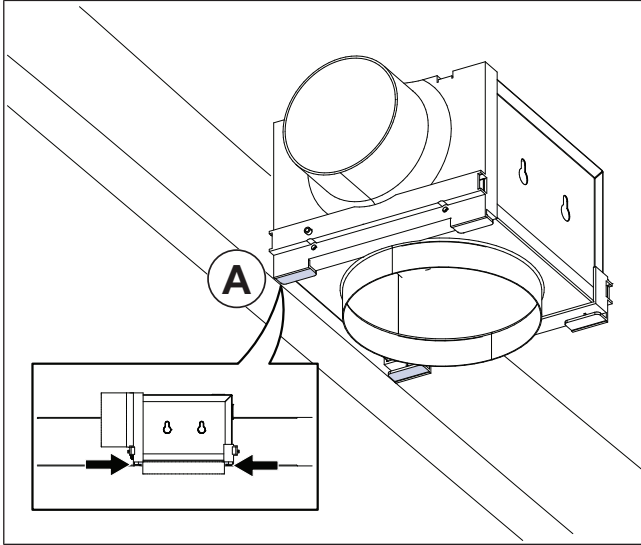

- 2 Use two (2) wood screws (A) to install the canister directly to the ceiling joist.

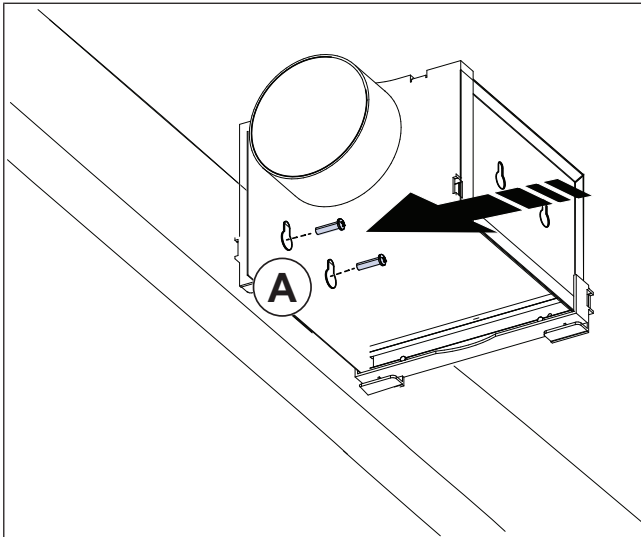

- 3 When ceiling material is installed, cut a 6 in. (152 mm.) hole for the ceiling grille.

For Retrofits or When Drywall is Installed

- 1 If necessary, remove the keyhole knockouts (A) and the electrical knockout.
- 2 Cut a 6 in. (152 mm.) hole (B) in the ceiling.
- 3 Refer to the canister installation sections to see how to install the canister in the attic.
- 4 If applicable, remove the electrical cover inside the canister.
- 5 To connect power, refer to the section [10.2 Wiring Diagram Overview](#).
Obey all local and applicable codes.
- 6 To attach the ducts, refer to section [3.6 To Attach the Duct](#).
- 7 If applicable, install the bulb (B) carefully into the socket of the canister.
- 8 Install the grille (C) into the steel collar.
Push until the grille is tightly against the canister.

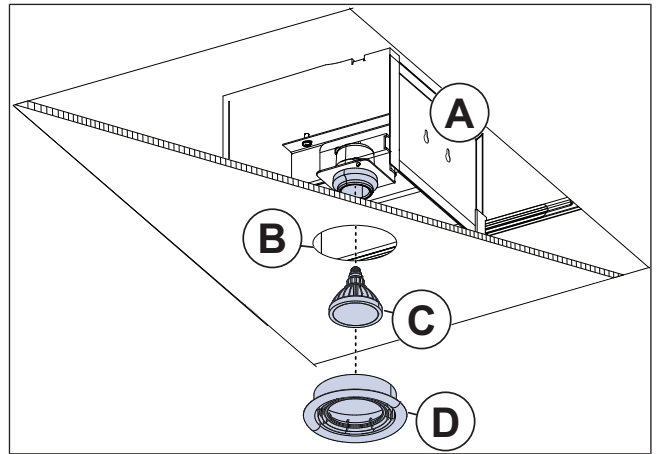

3.4 To Do Before the Installation of the Duct Run



Caution

To make sure the duct pressurizes, a correct duct termination device, such as a roof or wall cap, louvred shutters, or another device must be used with the product.

Note:

To keep pressure losses to a minimum, prevent air leakage, and promote sufficient airflow, obey the guidelines that follow:

- Keep the number of elbows and bends to a minimum.
 - If necessary, long radius elbows or bends are recommended.
- Make sure duct sealant, caulk, or tape is applied to all seams.
 - This includes around the interior opening in the wall or ceiling and around exterior building penetrations.
- You can use flexible, spiral, or snap lock duct.
 - For optimal efficiency, use the correct kind of duct necessary to prevent duct bends.
 - If rigid duct is used, Fantech recommends to use FC Mounting Clamps to connect the duct to the product. These clamps will make air tight seals at the connection points and will decrease vibrations transmitted throughout the duct system.
- If you install this product in an unconditioned space, attach insulation to the product and to the duct to prevent condensation.
- To minimize static pressure losses and promote correct airflow, use short duct run lengths where possible.
 - If you use flex duct, keep duct runs straight and make sure the tension in the duct is correct.
- Use a minimum of 8 feet (2.4 meters) of insulated flexible duct between the intake canister/bye and the product for quiet operation.
- Keep the product as far away from the exhaust hood as possible.

3.5 To Attach the Duct without Mounting Clamps

Note:

If your product has mounting clamps, refer to section 3.6 To Attach the Duct.

- 1 Use 1/4 in. (6 mm.) sheet metal screws to attach duct to the product.
- 2 Safety both the inlet and outlet with duct tape.

3.6 To Attach the Duct

To Attach the Duct to the Product

Note:

Refer to the FC Mounting Clamp installation manual (#450222) for more installation instructions.

- 1 Put the ducts on each side of the product.
- 2 Use 1/4 in. (6 mm.) sheet-metal screws, and FC Mounting Clamps (A) to attach the duct to product.
- 3 Tighten the clamps (A) around the duct and the product with the supplied screws. Make sure that there is a distance between the duct and the product to decrease vibrations transmitted from the product to the duct system.

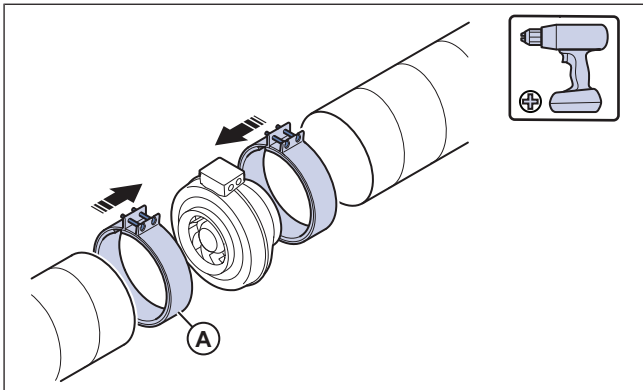

A. FC Mounting Clamps

- 1 If you install the product near a duct bend, do these steps to prevent vibrations, unwanted noise, and decreased air pressure:
 - a. Measure the distance (A) between the product and the duct bend.
 - b. Make sure that the distance (A) is a minimum of 2.5 x the diameter (B) of the duct system. For circular ducts, (B) is the nominal diameter. For rectangular ducts, (B) is the hydraulic diameter.

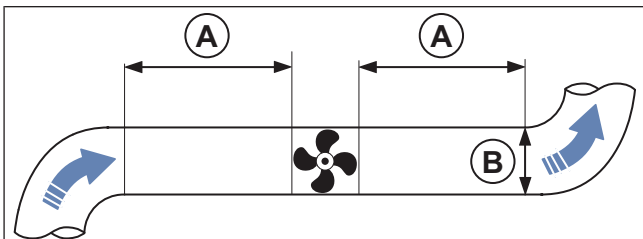

- A. Distance between product and duct bend.
 B. Diameter of duct system

To Attach the Duct to the Wye/Canister

Note:

Use a minimum of 8 feet (2.4 meters) of insulated flexible duct between the intake canister/wye and the product for quiet operation.

- 1 Install the correct sized duct from the product to the canister/wye.
- 2 If applicable, attach ducts to each opening of the wye and to each canister.
- 3 Safety ducts to their related openings and seal.
- 4



Caution
 Make sure the insulation material is covered.

If applicable, seal the inner liner of flexible insulated duct to the related opening. Then, seal the outer shell over the top of the inner liner.

3.7 To Manage the Duct Run

- 1 Use duct tape to attach additional ducts to the product to make sure air is released to the outdoors.
- 2 Find the shortest and straightest direction to the outdoors. Then, install the duct run through the roof or through the wall.
- 3 If the duct was installed through the roof, attach a correctly-sized roof cap to the end of the duct run.
- 4 If the duct was installed through the wall, attach a correctly-sized wall cap to the end of the duct run.
- 5 Install insulation around the product's casing.
- 6 With sealant, close all gaps between the support frames and the product's casing.

4 Electrical connection

4.1 To connect the product to the power supply

- Make sure that the electrical connection agrees with the product specification on the motor name plate.
- Make sure that the environment for electrical connection is clean and dry.
- Make sure that the wiring diagram that is included with the product agrees with the terminals in the connection box.
- Complete the electrical connection for the motor. Refer to the motor wiring diagram that is included with the product.
- Make sure that the cross section of the protective grounding is equal to or larger than the cross section of the phase conductor.

4.2 Speed controller for AC motors

Note:

The speed controller alternatives are different for different motor types. Make sure that your motor is compatible with the speed controller type before you use it.

4.3 Motor Protection

The product has integrated auto reset motor protection. If the product overheats, it will stop automatically. Once the temperature of the product cools down, the product will operate normally again.

5 Operation

5.1 To Start the Product with an AC Motor

- 1 Install the external speed controller. Refer to the instruction manual for the installed speed controller.
- 2 Set the switch(es) in the ON position.

5.2 To Start the Product with an EC Motor

- 1 Make sure that the 0–10 V signal is set to “0” with the external speed controller.
- 2 Apply line voltage to the product, and wait 5 seconds.
- 3 Adjust the product speed with a 0–10 V DC signal speed controller. If an external speed controller is not installed, adjust the speed directly with the built-in potentiometer.

5.2.1 To Stop the Product

- 1 Set the switch(es) in the OFF position.

6 Commissioning



Caution

- If strong vibrations occur during commissioning, immediately increase or decrease the fan speed until the vibrations are decreased. Continuous strong vibrations can cause damage to components.
- Do not increase the fan speed to a higher rpm value than the maximum value that is given on the name plate.

6.1 To Do Before the Commissioning

- Make sure that the installation and electrical connection are correctly done.
- Visually examine the product and accessories for damage.
- Make sure that there are no blockages in the air inlet and the air outlet.
- Make sure that installation material and unwanted objects are removed from the product and the ducts.

6.2 To Do the Commissioning

- 1 If it is possible to get access to the fan impeller, do the steps that follows:
 - a. Turn the fan impeller by hand and make sure that it turns easily.
 - b. Make sure to turn the product in a direction that agrees with the related arrow on the product.
- 2 Start the product.
- 3 If applicable, set the minimum operation speed.
- 4 Increase the operation speed gradually to the maximum operation speed.
 - a. Examine the vibrations in the casing and the bearing areas at all speed levels.
 - b. Make sure that none of the speed levels cause unwanted noise in the product.
- 5 Stop the product.

7 Maintenance



Warning

Set the installed switch(es) in the OFF position before you do the maintenance unless the instructions tell you differently. Make sure that the switch(es) is not accidentally set in the ON position.

7.1 Maintenance Schedule

The intervals are calculated from continuous operation of the product.

| Maintenance task | Usual operation conditions | | Unusual operation conditions ¹ | | |
|----------------------------------------------------------------------------------------------------------------------|----------------------------|-----------|-------------------------------------------|---------------|-----------|
| | Each 6 months | Each year | Each 3 months | Each 6 months | Each year |
| Visually examine the product and its components for damage, corrosion and dirt. | | X | | X | |
| Examine the fan impeller for damage and imbalance. | | X | | X | |
| Clean the product and the ventilation system. | X | | X | | |
| Do a check of all fasteners and make sure that they are fully tightened. | | X | | | X |
| Make sure that the product and its components are correctly operated. | X | | | X | |
| Measure the power consumption and compare the result with the information on the name plate. | | X | | X | |
| If vibration dampers are installed, make sure that they operate correctly and examine them for damage and corrosion. | | X | | | X |
| Make sure that the electrical protective equipment and the mechanical protective equipment operates correctly. | | X | | | X |
| Make sure that you can read the name plates of the product. | | X | | X | |
| Examine all cable connections for damage. Make sure that the cable glands are tight against the cables. | | X | | | X |
| If flexible connections are installed, examine them for damage. | X | | | X | |

1. The unusual operation conditions are classified as follows: If a stable ambient temperature is higher than 80°F or lower than 14°F, if the temperature changes are large, or if very contaminated air is transported.

7.2 Spare Parts

Note:

Make a scan of the code that follows to get access to our spare parts portal.

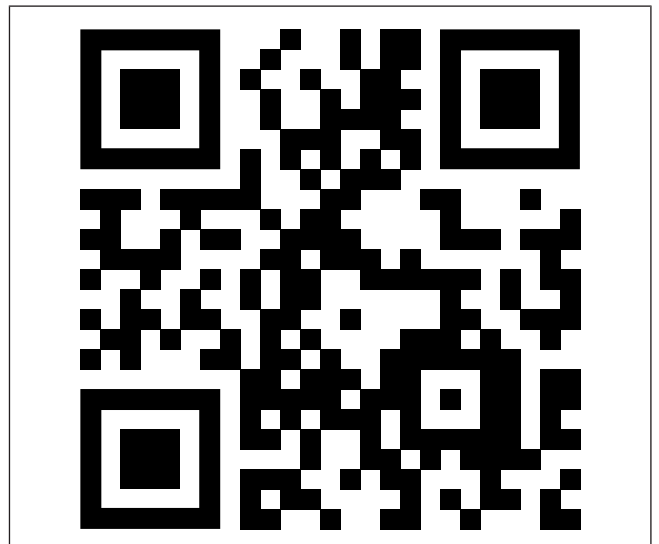

7.3 To clean the product



Caution

Before you clean the product, obey the guidelines that follow:

- Do not clean the product with a high-pressure washer.
- Do not clean the product with steel brushes or sharp objects.
- Do not bend the product impeller blades.
- Be careful not to move the balance weights on the product impeller.

Note:

To clean the product, obey the guidelines that follow:



- Remove dirt from the product and the duct.
- If access to the product impeller is possible, clean the impeller with a moist cloth or soft brush.

8 Troubleshooting

Note:

If you cannot find a solution to your problem in this section, speak to Fantech technical support.

| Problem | Cause | Solution |
|---------------------------------------------------------------|-----------------------------------------------------------------------------------------------------|-------------------------------------------------------------------------------------------------------------------------------------|
| The product does not operate smoothly. | The fan impeller is not correctly balanced. | Speak to Fantech technical support. |
| | There is dirt on the fan impeller. | Clean the fan impeller carefully. Refer to section 7.3 To clean the product. |
| | The fan impeller does not turn in the correct direction. | Make sure that the electrical connection is done correctly. |
| | The fan impeller has damages or deformations because the transported air contains aggressive media. | Speak to Fantech technical support. |
| | The fan impeller has deformations because of too high temperatures. | Replace the product. |
| | There are unusually strong vibrations in the product or the duct system. | Make sure that the product is correctly installed. Do a check of the duct system. |
| | The product is operated in a resonant frequency range. | Increase or decrease the fan speed until the product operates smoothly. |
| The air output is not sufficient. | The air pressure is too low because of incorrect installation. | Do the necessary changes in the duct system and installed components to increase the air pressure. |
| | The airflow shutters are closed or not fully open. | Adjust airflow shutters (if applicable). |
| | There is blockage in the air inlet or the duct system. | Remove the blockage. |
| | The product is not applicable for the installation location. | Make sure that the product is applicable for the installation location. |
| | The motor power is decreased because of too high temperature in the motor. | <ul style="list-style-type: none"> Do a check of the ambient temperature. |
| There is unusual noise when the product starts or operates. | There is strain in the connections of the duct system. | Loosen the connections, align the parts of the duct system correctly and tighten the connections. |
| Thermal contacts, PTC or resistors are released. | The motor is overheated. | <ul style="list-style-type: none"> Do a check of the motor hub for dust. If necessary, clean the motor hub. |
| | There is blockage in the motor. | Speak to Fantech technical support. |
| | The capacitor is not connected or not correctly connected. | Connect the capacitor correctly. Refer to the included motor wiring diagram. |
| <p>Note: This is not applicable for EC motors.</p> | | |

| Problem | Cause | Solution |
|-------------------------------------------------------|---------------------------------------------------------------------|------------------------------------------------------------------------------------------------------------------------------------------------------------------------------------------------------------------------------|
| The fan speed does not get the nominal value. | Defective motor winding. |  Caution Set the installed switch to the OFF position. A fan replacement may be necessary. Speak to Fantech technical support. |
| | The speed control is not correctly set. | Set the speed control correctly. |
| | The fan impeller cannot turn freely because of mechanical blockage. | Remove the blockage. |
| The motor does not rotate. | A component in the power supply is defective. | Do a check of the power supply. Replace defective components and connect the power supply again. |
| | The electrical connection is not correctly done. | Make sure that the electrical connection agrees with the wiring diagrams. |
| | The motor protection is released because the motor is overheated. | Let the motor become cool. Find the cause of the overheated motor. |
| The electronic components or the motor is overheated. | The motor is overloaded or the ambient temperature is too high. |  Caution Set the installed switch to the OFF position. A fan replacement may be necessary. Speak to Fantech technical support. |
| | The motor is overloaded. | Make sure that the product is applicable for the installation location. |
| | The ambient temperature is too high. | Make sure that the product is applicable for the installation location. |

9 Disposal

The product must be recycled at an approved disposal location for electrical and electronic equipment.

10 Technical data

10.1 Technical Data Overview

| | |
|-----------------------------------------|---------------------------------------------------------------------------------------------------|
| Max. temperature of transported air, °F | 140 |
| IP class | Refer to the data sheet on the online catalogue at Fantech.net . |
| Voltage, current, frequency | Refer to the nameplate. Refer to section 1.6 Nameplate for more information. |
| Motor data | Refer to the motor nameplate or the technical documentation from the motor manufacturer. |

10.2 Wiring Diagram Overview



Caution

Wire these installations according to the following diagrams. Failure to comply can cause the motor to fail.



Caution

The maximum torque that can be applied to the terminal block screws is 0.79 Nm (7 lb-in). Over-torquing the terminal block screws can cause the motor to fail.

Note:

Refer to the diagrams that follow for wiring instructions.

10.2.1 Wiring Diagrams for AC Fans

| Legend for Diagram | |
|---------------------|---------------------------------|
| English Terminology | Meaning |
| BL | Blue |
| BK | Black |
| BK TERM | Black Terminal |
| BR | Brown |
| BRA TERM | Brass Terminal |
| CAP | Capacitor |
| GND | Ground |
| GR | Green |
| GR / Y | Green / Yellow |
| L | Line |
| LL | Light Leads |
| LO | Load |
| MLS | Main Light Switch |
| MTR | Motor Wires |
| N | Neutral |
| S1 | Sensor 1 |
| SLS | Secondary Light Switch |
| SV | Supply Voltage |
| T1 | Timer 1 |
| TB | Terminal Blocks |
| TR | Traveler |
| W | White |
| 120V AC SUP | 120V Alternating Current Supply |
| / | Or |

Note:

Wire order can differ.

Note:

Connect Neutral, Line, and Ground (if applicable) to the correct motor colors.

Note:

Terminate the end of the Red/Yellow wire on each switch.

To Connect Power to the LED Lamps

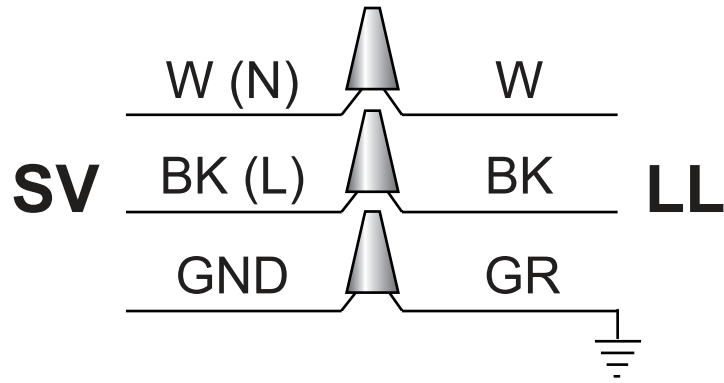

Note:

Line and load wires can be connected interchangeably for this product.

To Connect a Count-down Timer to the PB 110 Series (Single Location)

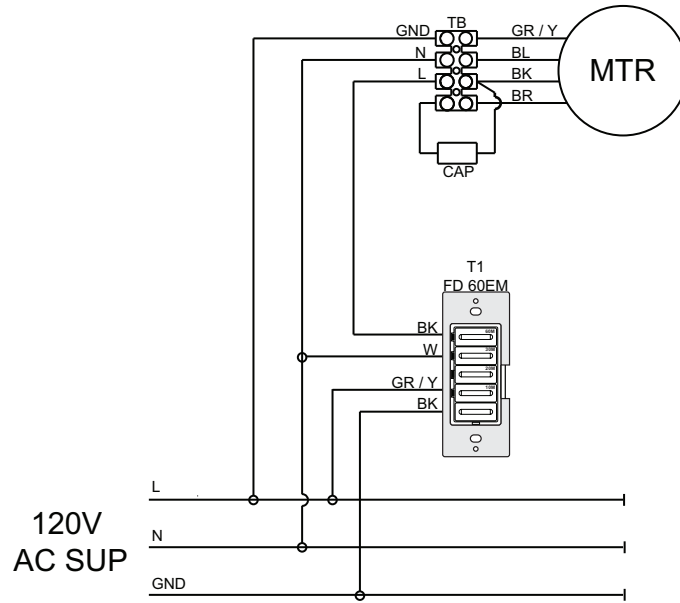

To Connect a Humidity Sensor to the PB 110 Series (Single Location)

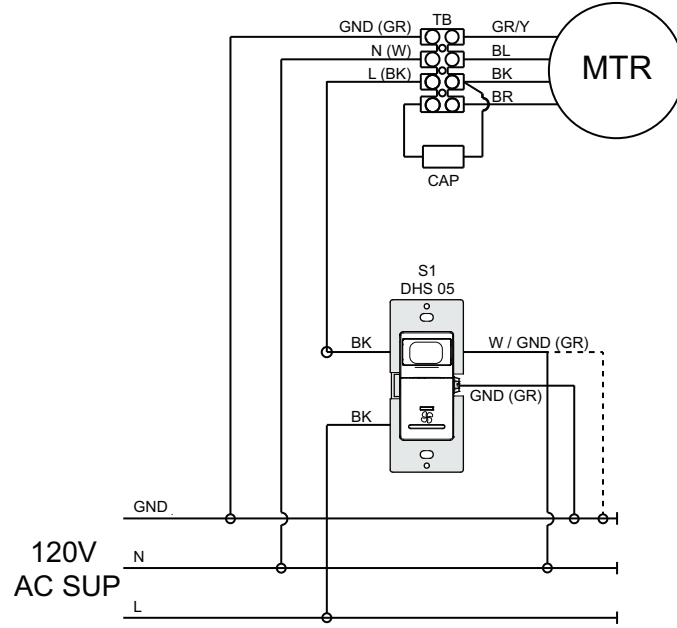

To Connect Two Light Switches to the PB 270 Series and the PB 370-2, #45433 (Dual Location)

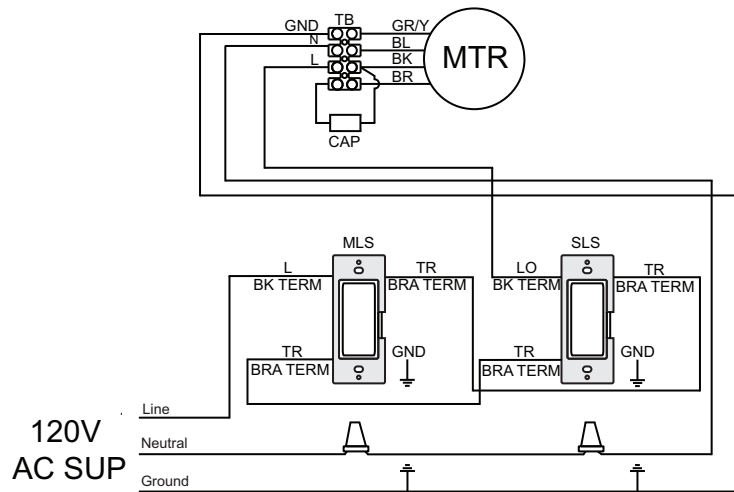

10.3 Product Dimensions

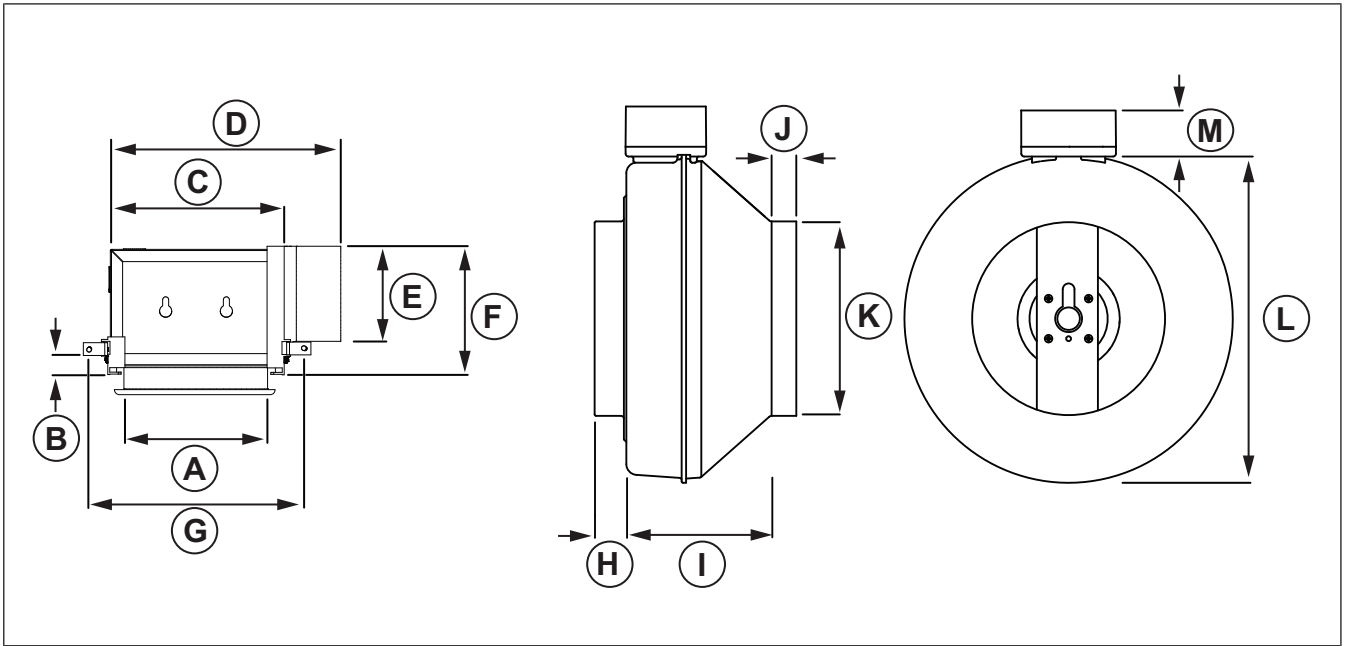

| | A | B | C | D | E | F | G |
|--------------------------------------------------------------------------------------------------------------------------------------------------------------------------------------------------------------------------------|---------------|-------------|--------------|--------------|--------------|--------------|---------------|
| <ul style="list-style-type: none"> • PB 110, #40568 • PB 110 L7, #44942 • PB 110 L10, #44943 | 5 13/16 (148) | 13/16 (21) | 7 3/16 (183) | 9 9/16 (243) | 4 (102) | 5 5/16 (134) | 8 15/16 (227) |
| | H | I | J | K | L | M | |
| | 1 (25) | 6 1/2 (165) | 1 (25) | 4 (102) | 8 1/2 (216) | 2 (52) | |
| | A | B | C | D | E | F | G |
| <ul style="list-style-type: none"> • PB 270-2, #40572 • PB 270L7V2, #44946 • PB 270L7-2, #44944 • PB 270L10V2, #44947 • PB 270L710-2, #44948 • PB 270L10-2, #44945 | 5 13/16 (148) | 13/16 (21) | 7 3/16 (183) | 9 9/16 (243) | 4 (102) | 5 5/16 (134) | 8 15/16 (227) |
| | H | I | J | K | L | M | |
| | 1 (25) | 6 1/4 (159) | 7/8 (22) | 6 (152) | 11 3/8 (289) | 2 (52) | |

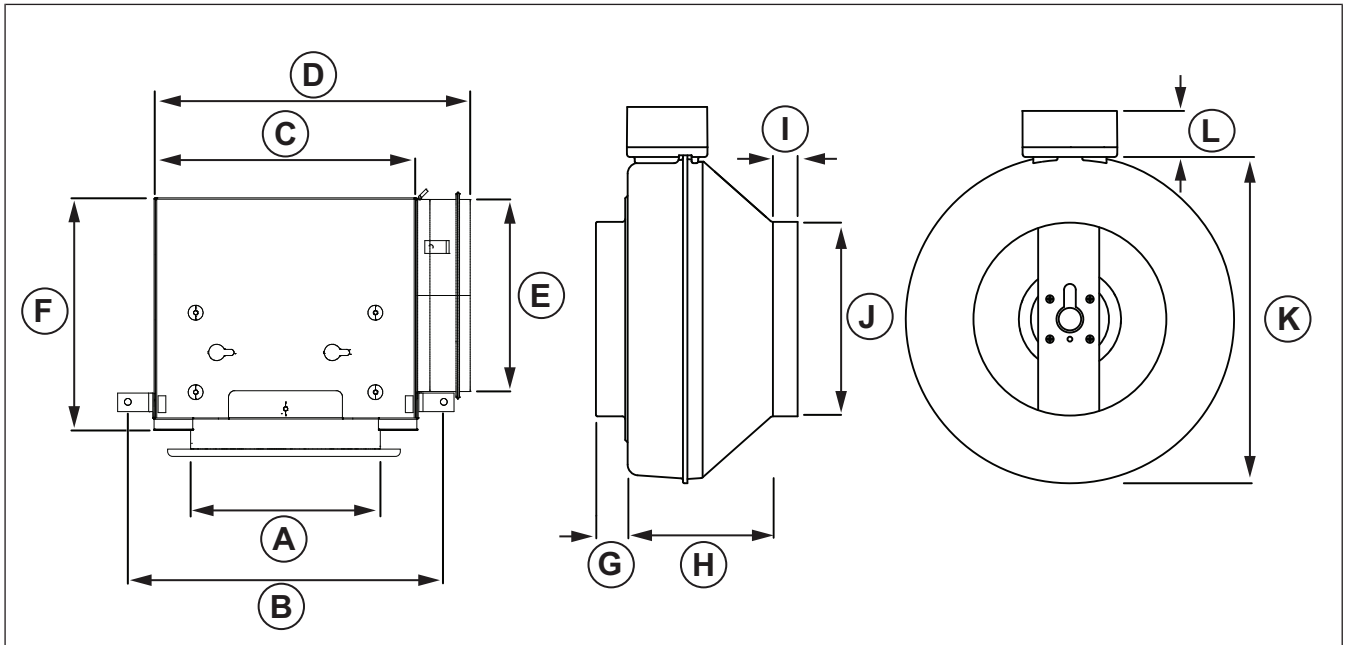

Note:

Dimensions are given in inches (mm).

| | A | B | C | D | E | F |
|--------------------|---------------|-------------|----------|---------------|---------------|-------------|
| • PB 190, #40571 | 5 13/16 (148) | 9 (230) | 8 (204) | 9 13/16 (249) | 5 15/16 (151) | 7 1/4 (184) |
| | G | H | I | J | K | L |
| | 1 (25) | 6 1/4 (159) | 7/8 (22) | 6 1/4 (159) | 11 3/8 (289) | 2 (52) |
| | A | B | C | D | E | F |
| • PB 370-2, #45433 | 5 13/16 (148) | 9 (230) | 8 (204) | 9 13/16 (249) | 5 15/16 (151) | 7 1/4 (184) |
| | G | H | I | J | K | L |
| | 1 (25) | 7 (178) | 1 (25) | 6 (152) | 13 1/8 (333) | 2 (52) |



fantech[®]
a systemair company

USA

(800) 747 1762

support@fantech.net

Canada

(800) 565 3548

support@fantech.net

Latin America

+52 55 1328 7328

support@fantech.net

© Copyright Fantech

All rights reserved

Fantech reserves the rights to alter their products without notice. This also applies to products already ordered, as long as it does not affect the previously agreed specifications.