



Bosch IDS Family of Inverter Heat Pumps

Quick Start Guide



The robust Bosch Inverter Ducted Split Air Source Heat Pump system utilizes just the right amount of energy to achieve ultimate comfort at maximum efficiency while keeping sound levels to a minimum.

- ▶ Designed for easy installation & start-up
- ▶ Support & spare parts readily available
- ▶ Easy to maintain & service



Bosch IDS Family

Smarter Comfort, Greater Efficiency, Every Season!

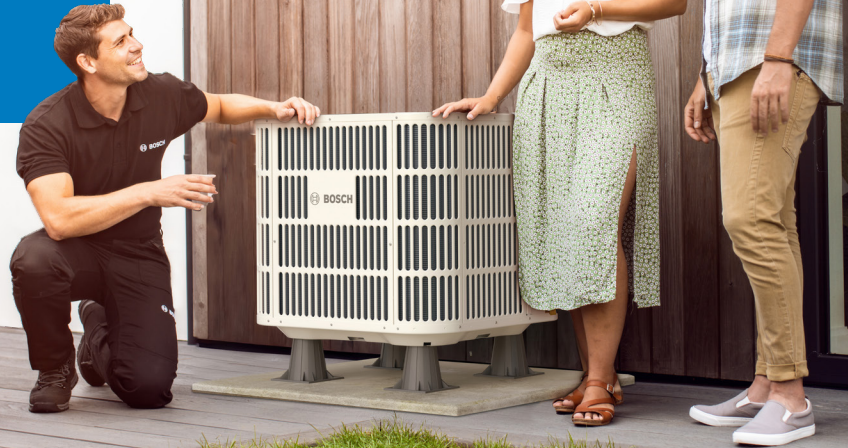

The Complete Lineup of Bosch IDS Inverter Ducted Split Systems

Give your customers what they want: quiet, reliable, energy-efficient comfort all year long. From entry-level to advanced connected solutions, the Bosch IDS Family delivers options for every home, every climate, and every budget.



Versatile Lineup

Four systems ranging from 15 to 20 SEER2, covering 24K to 60K BTU capacities.



Inverter Technology

Fully modulating compressors use only the energy needed, reducing wear and extending system life.



Quiet Operation

With sound levels as low as 56 dBA, homeowners enjoy peace and comfort.



Cold Climate Ready

IDS Ultra provides heating down to -13°F.



Strong Warranty Protection

10-year residential limited warranty on parts plus coverage for connectivity components on select models.



Smart Connectivity

Premium Connected and Ultra models offer remote monitoring, troubleshooting, and easy warranty registration through the Bosch EasyAir app.



Dual Fuel Solutions

Pair with the Bosch BGH96 Furnace for maximum efficiency and peace of mind in harsh winters.



Installer Friendly

Compact footprint, intuitive controls, in-app installation guides, and easy service access save you time on the job.



Trusted Bosch Engineering

Durable all-aluminum coils, corrosion-resistant cabinets, and Bosch's rigorous testing standards



IDS Light

Entry-Level Efficiency

- ▶ Up to 15.2 SEER2 / 8.5 HSPF2 for energy savings
- ▶ Quiet operation as low as 59 dBA
- ▶ Compact footprint for easy installation in tight spaces
- ▶ Compatible with most 24V thermostats
- ▶ Bosch inverter technology for steady comfort and reduced energy use
- ▶ Dual fuel capable with Bosch BGH96 Gas Furnace
- ▶ All-aluminum coils for durability and reduced leak risk
- ▶ Backed by a 10-year residential limited warranty



IDS Plus

Enhanced Performance at a Great Value

- ▶ Up to 18 SEER2 / 8.5 HSPF2 for affordable efficiency
- ▶ Ultra-quiet operation as low as 56 dBA
- ▶ Two-stage ECM blower motor for better humidity control
- ▶ Fully modulating inverter drive for precise comfort
- ▶ ENERGY STAR® rated for rebates and incentives
- ▶ Simple, installer-friendly design with onboard diagnostics
- ▶ Dual fuel pairing for optimal comfort in colder climates
- ▶ 10-year parts warranty for peace of mind



IDS Premium Connected

Smart, High-Efficiency Comfort

- ▶ Up to 20 SEER2 / 9.5 HSPF2 – Bosch's highest efficiency
- ▶ Bosch EasyAir app for remote monitoring and troubleshooting
- ▶ Wireless connectivity for fast setup and diagnostics
- ▶ Sound levels as low as 60 dBA
- ▶ Variable-capacity inverter compressor adapts between 35% and 138% output
- ▶ Qualifies for maximum rebates and incentives
- ▶ Dual fuel ready with Bosch BGH96 Gas Furnace
- ▶ 10-year limited warranty plus connectivity component coverage



IDS Ultra

Cold Climate Champion

- ▶ Cold climate performance: 100% heating capacity at 5°F, reliable to -13°F
- ▶ Up to 19 SEER2 / 10.0 HSPF2 for maximum year-round comfort
- ▶ DOE Cold Climate Heat Pump Challenge approved
- ▶ Enhanced Vapor Injection (EVI) compressor for powerful low-temp heating
- ▶ Bosch EasyAir app for remote monitoring and fast troubleshooting
- ▶ Quiet operation with sound isolating mounts and blade technology
- ▶ Dual fuel capability for added peace of mind in extreme cold
- ▶ 10-year parts warranty plus EasyAir connectivity coverage



	IDS LIGHT	IDS LIGHT	IDS PLUS	IDS PREMIUM CONNECTED	IDS ULTRA
SEER2 / HSPF2	Up to 16 / 9	Up to 15.2 / 8.5	Up to 18 / 8.5	Up to 20 / 9.5	Up to 19 / 10.0
Sound Levels	As low as 59 dBA		As low as 56 dBA	As low as 60 dBA	
Capacity Range	18K to 36K BTU	24K to 60K BTU			48K to 60K BTU
Compressor Technology	Variable capacity inverter (33%-128%)			Variable capacity inverter (35%-138% speed in cooling, 34%-130% speed in heating)	EVI Variable capacity inverter (33%-187%)
Motor Type	Single-stage Constant Torque ECM	Single-stage PSC Motor	Two-stage ECM Motor for enhanced humidity control		Four-stage 10 speed ECM Motor for superior humidity control
2-Wire Communicating	Default				
24V AC Capability	Yes				
Smart Connectivity	Not Available		Bosch EasyAir App: remote monitoring, troubleshooting, warranty registration		
Cold Climate Performance	Standard performance in moderate climates		Standard performance, high efficiency in all climates		Cold climate performance: 100% heating at 5°F, operates to -13°F
Dual Fuel Capability	Not Available	Available with BGH96 Furnace			
Electric Heat Strips	1 & 2 Stage Available			2 Stage Available	3 Stage Available
Coil Design	All-aluminum coil for durability and efficiency				
Cabinet Construction	Galvanized steel cabinet with salt spray test durability	Painted galvanized steel cabinet, corrosion-resistant			
Diagnostics & Serviceability	Intuitive controls and easy maintenance		On-board diagnostics, mobile app installation guides & remote fault code monitoring		
Rebate & Incentive	ENERGY STAR qualified, pairings available		Qualifies for maximum rebates and tax credits		ENERGY STAR Cold Climate Certified; DOE Challenge Approved
Warranty	10-year parts warranty		10-year parts + connectivity coverage		
Key Benefits	Affordable entry-level inverter system ideal for multi-family	Affordable entry-level inverter system ideal for budget-conscious homeowners	Enhanced efficiency and quieter operation at a competitive price point	Enhanced efficiency and quieter operation at a competitive price point	Top-tier efficiency with smart connectivity and maximum rebate potential

Engineered for Performance. Built for Contractors. Trusted by Homeowners.

Every component of the Bosch IDS Family is designed with precision engineering to deliver reliable comfort, simplified installation, and long-lasting efficiency.

The Bosch Inverter Ducted Split (IDS) Family sets a new standard for heating and cooling. From high-efficiency condensers to space-saving air handlers, every system is engineered for comfort, quiet performance, and easy serviceability.

With durable all-aluminum coils, precision inverter compressors, and smart control boards, Bosch delivers lasting reliability and efficiency. Multiple air handler options, traditional, wall-mounted, or ceiling-mounted, make it easy to meet any home's needs.

Installer-friendly features like intuitive controls, onboard diagnostics, and in-app support help you save time, reduce callbacks, and deliver the comfort homeowners expect.



IDS Components Features & Benefits

Intelligent Control Features

Automatically adjust system output to maintain consistent comfort and humidity control year-round.

High-Efficiency Inverter Compressor

Modulates in precise increments for maximum efficiency and energy savings.

Smart Connectivity (Premium Connected & Ultra)

Wireless setup, remote monitoring, troubleshooting, and warranty registration via the Bosch EasyAir app.

PSC / ECM / Constant Torque Motors

Efficient, reliable blower options to match system performance needs.

Electric Heat Capability

Easily accommodate electric heat strips for additional comfort on demand.

All-Aluminum Coil

Superior heat transfer and durability with reduced risk of refrigerant leaks.

Advanced ECM Blower Motor (Ultra)

Four-stage motor provides enhanced comfort, superior humidity control, and energy savings.

Control Board Pocket

Protected location shields the control board from moisture, extending its lifespan.

Integrated Drain Pan

Corrosion-resistant, sloped design reduces standing water and ensures long-term reliability.

Filter Rack

Factory-installed for easy serviceability and improved indoor air quality.

Corrosion-Resistant Cabinets

Rugged galvanized steel tested for durability and long-lasting performance.



The Complete & Highly Efficient Dual Fuel Heating and Cooling System For Your Home



A Bosch BGH96 96% Furnace*

The BGH96 Gas Furnace offers up to 96% efficiency, a two-stage gas valve, and a multi-speed blower and a blower built with constant air flow technology. This ENERGY STAR rated furnace offers premium comfort and energy savings, it is the perfect solution to efficiently heat your home. Compatible with R-454B heat pump systems.



B Bosch BMAC Cased Coil*

The Inverter Ducted Split Cased Coil, when paired with a Bosch Furnace and IDS outdoor condensing section, delivers some of the best comfort levels and efficiency on the market today. Bosch offers a complete range of cased coils to fit your needs.



C LGWP IDS Outdoor unit*

The robust Bosch Inverter Ducted Split Air Source Heat Pump system utilizes just the right amount of energy to achieve ultimate comfort and maximum efficiency while keeping sound levels to a minimum. Choose from one of three options



D Bosch BCC110 Wi-fi Thermostat*

The BCC110 is a sleek, internet-connected thermostat that offers easy all-in-one control for your heating and cooling systems. It can be controlled using the Bosch EasyAir app and is compatible with most 24VAC HVAC equipment on the market.

Bosch IDS Dual Fuel Provides Optimal Comfort Every Season!

An Ideal Solution to Maximize Comfort & Efficiency

Bosch offers a complete dual fuel heating and cooling system for your home. Dual fuel systems are the ideal solution to maximize comfort and efficiency. In the summer, the Bosch IDS efficiently cools and dehumidifies your home. In the colder months, the system senses when it is more economical for the heat pump to shut off and the Bosch BGH96 gas furnace to take over. Installing a Bosch matched dual fuel system is the best choice to optimize both savings and comfort.



Bosch Dependable and Multi-Positional Cased Coils

The Inverter Ducted Split Evaporator Coil, when paired with a furnace along with an IDS outdoor condensing section, will deliver some of the best comfort levels and efficiency on the market today. Bosch offers a complete range of cased evaporator coils to fit your needs. Have peace of mind knowing that all Bosch cased coil models include a 10-year parts residential warranty.⁵



Cased Evaporator Coil

The cased evaporator coils include easy-to-clean foil-back insulation which helps to ensure against energy loss through the cabinet as well as keeping the unit quiet. Bosch offers a complete range of 10 evaporator coil models from 2 through 5 ton sizes, in all orientations including upflow, downflow and horizontal to fit all duct sizes and meet your needs. Bosch cased coils can be easily installed for retrofit or new construction applications using the simple slide-out feature. The cased evaporator coils are constructed from all-aluminum fins with aluminum tubing to help prevent formicary corrosion while maintaining high heat transfer efficiency thereby increasing longevity and cost savings.



Choose Your Heat Pump Different Options & Price Points

IDS Light Outdoor Unit



- ▶ First 15-SEER Inverter on the market
- ▶ Inverter system at a price point you'll love!
- ▶ Robust design
- ▶ Small footprint
- ▶ Quiet sound levels
- ▶ Compatible with most 24V thermostat

Premium Connected Outdoor Unit



- ▶ premium 20-plus SEER energy efficiency
- ▶ Features wireless connectivity
- ▶ Compatible with Bosch EasyAir app
- ▶ Robust design
- ▶ Small footprint
- ▶ Quiet sound levels
- ▶ Compatible with most 24V thermostat

IDS Ultra Outdoor Unit



- ▶ Cold Climate Heat Pump
- ▶ 100% heating capacity down to 5°F
- ▶ DOE Challenge approved
- ▶ Gateway communication to Cloud
- ▶ Robust Design
- ▶ Small footprint
- ▶ Quiet sound levels
- ▶ Compatible with most 24V thermostat

BOSCH IDS FAMILY DESCRIPTION & DIMENSIONS^o

MODEL NUMBER	DESCRIPTION	PART NUMBER	WIDTH (W)	HEIGHT (H)	DEPTH (D)
BOVA15 OUTDOOR CONDENSING SECTION					
BOVA-24RXB-M15S	24 kBTU/hr (2 ton)	8733965412	28.00	24.938	28.000
BOVA-36RXB-M15S	36 kBTU/hr (3 ton)	8733965413	28.00	24.938	28.000
BOVA-60RXB-M15S	60 kBTU/hr (5 ton)	8733965414	29.125	33.188	29.125
BIVA15 INDOOR AIR HANDLER					
BIVA-24RXB-M15X	24 kBTU/hr (2 ton)	8733965419	19.625	46.5	21.625
BIVA-36RXB-M15X	36 kBTU/hr (3 ton)	8733965420	19.625	46.5	21.625
BIVA-48RXB-M15X	48 kBTU/hr (4 ton)	8733965421	22.0	54.5	24.0
BIVA-60RXB-M15X	60 kBTU/hr (5 ton)	8733965422	22.0	54.5	24.0
BIWA16 INDOOR AIR HANDLER					
BIWA-18RXB-M16X	18 kBTU/hr (1.5 ton)	8733965439	20.5	36.5	15
BIWA-24RXB-M16X	24 kBTU/hr (2 ton)	8733965440	20.5	36.5	15
BIWA-30RXB-M16X	30 kBTU/hr (2.5 ton)	8733965441	22	39.5	19
BIWA-36RXB-M16X	36 kBTU/hr (3 ton)	8733965442	22	39.5	19
BICA16 INDOOR AIR HANDLER					
BICA-18RXB-M16X	18 kBTU/hr (1.5 ton)	8733965443	37.25	10.5625	26.3125
BICA-24RXB-M16X	24 kBTU/hr (2 ton)	8733965444	37.25	10.5625	26.3125
BICA-30RXB-M16X	30 kBTU/hr (2.5 ton)	8733965445	49.25	10.5625	26.3125
BICA-36RXB-M16X	36 kBTU/hr (3 ton)	8733965446	49.25	10.5625	26.3125
BOVA20 OUTDOOR CONDENSING SECTION					
BOVA-36RTB-M20S	36 kBTU/hr (3 ton)	8733965410	29.125	24.9375	29.125
BOVA-60RTB-M20S	60 kBTU/hr (5 ton)	8733965411	29.125	33.1875	29.125
BIVA20 INDOOR AIR HANDLER					
BIVA-24RCB-M20X	24 kBTU/hr (2 ton)	8733965415	19.625	46.5	21.625
BIVA-36RCB-M20X	36 kBTU/hr (3 ton)	8733965416	19.625	46.5	21.625
BIVA-48RCB-M20X	48 kBTU/hr (4 ton)	8733965417	22.0	54.5	24.0
BIVA-60RCB-M20X	60 kBTU/hr (5 ton)	8733965418	22.0	54.5	24.0
ULTRA SERIES OUTDOOR CONDENSING SECTION					
BOVA-60MTB-M19E	60 kBTU/hr (5 ton)	8733958901	29.125	43.3125	29.125
ULTRA SERIES INDOOR AIR HANDLER					
BIVA-48MCB-M19X	48 kBTU/hr (4 ton)	8733958904	22.0	54.5	24.0
BIVA-60MCB-M19X	60 kBTU/hr (5 ton)	8733958905	22.0	54.5	24.0

BGH96 FURNACE DIMENSIONS^o

MODEL NUMBER	PART NUMBER	WIDTH (W)	HEIGHT (H)	DEPTH (D)
BGH96M060B3C	8733965433	17.5	33-3/4	28-1/2
BGH96M080B3C	8733965434			
BGH96M080C4C	8733965435	21		
BGH96M100C5C	8733965436			
BGH96M100D5C	8733965437	24.5		
BGH96M120D5C	8733965438			

BMAC CASED COIL DIMENSIONS ^o		CASED			UNCASED		
MODEL NUMBER	PART NUMBER	WIDTH (W)	HEIGHT (H)	DEPTH (D)	WIDTH (W)	HEIGHT (H)	DEPTH (D)
BMAC2430ABTA	8733965423	14.5	20.0	21.0	13.375	15.625	20.5
BMAC2430BBTA	8733965424	17.5	20.0	21.0	16.375	15.375	20.5
BMAC3036ABTA	8733965425	14.5	20.0	21.0	13.375	15.625	20.5
BMAC3036BBTA	8733965426	17.5	20.0	21.0	16.375	15.375	20.5
BMAC3036CBTA	8733965427	21.0	20.0	21.0	19.875	15.25	20.5
BMAC4248BBTA	8733965428	17.5	30.0	21.0	16.375	26.88	21.0
BMAC4248CBTA	8733965429	21.0	30.0	21.0	19.875	26.8	21.0
BMAC4248DBTA	8733965430	24.5	30.0	21.0	23.625	26.6	21.0
BMAC4860CBTA	8733965431	21.0	30.0	21.0	19.875	27.0	21.0
BMAC4860DBTA	8733965432	24.5	30.0	21.0	23.625	26.8	21.0

The Next-Generation of Heating & Cooling

Bosch IDS Ultra

Our new cold climate heat pump for all seasons, even in sub-zero temperatures!

How Does the Bosch IDS ULTRA Work?
Scan to Watch Video

Line Sets and Charging

The Bosch condensers come factory pre-charged (R-454B) for 25' of standard size line set. For the BOV*20, up to 150' of line set is allowed with a maximum of 50' lift (refer to Figure 2.1). For the BOVA15 and BOVB18, up to 100' of line set is allowed with a maximum of 50' lift (refer to figure 2.2). Any Application with line set length of more than 25' would require an additional 0.6 oz/ft for each additional foot of line set (refer to Figure 2.2), this can be done by one of two methods: (1) Charge by Weight, (2) Charge by Subcooling.

Figure 2.1

System Capacity Model	Liquid Line	Suction Line	Light Total Equivalent Length-Feet				Premium & Ultra Total Equivalent Length-Feet					
			25	50	75	100	25	50	75	100	125	150
		Inch O.D.	Maximum Vertical Separation - Feet				Maximum Vertical Separation - Feet					
2 Ton	3/8 *	3/4 Std.	25	50	45	40	25	50	45	40	30	25
		5/8 Opt.	25	50	45	40	25	50	45	40	30	25
3 Ton	3/8 *	3/4 Std.	25	50	50	50	25	50	50	50	35	25
		5/8 Opt.	25	50	50	50	25	50	50	50	35	25
4 Ton	3/8 *	7/8 Std.	25	50	50	40	25	50	50	40	30	25
		3/4 Opt.	25	50	50	40	25	50	50	40	30	25
5 Ton	3/8 *	7/8 Std.	25	50	50	40	25	50	50	40	30	25
		3/4 Opt.	25	50	50	40	25	50	50	40	30	25
		1 1/8 Opt.	25	40	N/A	N/A	25	40	N/A	N/A	N/A	N/A

(1) Charge by Weight

Can be used at any time and is the recommended way to charge an IDS system (especially for initial installs). This method can be used when power is not available to the equipment site or when operating conditions are not in range to verify the charge based on subcooling. It is recommend to verify charge and adjust as necessary by subcooling. (Refer to Figure 2.4 for subcooling and superheat requirements.)

(2) Adjusting charge based on Subcooling & Superheating (AC Mode)

Outside temperature must be between 55° and 120°F and indoor temperature must be between 70° and 80°F to charge by subcooling. After starting the system in cooling mode, short press "FORCE" button (see Figure 2.3), "—" symbol Appears, and operate the system for a minimum of 20 minutes. (Refer to Figure 2.4 for subcooling and superheat requirements.)

Figure 2.3



Figure 2.2

1. Total Line Length (ft) = _____ (a)
2. Standard Lineset (ft) = 25 ft. (b)
3. (a) minus (b) = _____ (c)
4. Refrigerant Multiplier = 0.6oz/ft (d)
5. Refrigerant Adder (c*d) = _____ (e)*

*If lineset is less than 15 ft, (e) = 0

*From 15 ft to 25 ft

N/A: Application not recommended

Figure 2.4

DESIGN SUBCOOLING		
MODEL	SUBCOOLING/F°	SUPERHEAT/F°
24K/36K	6°-12°	6°-18°
48K/60K	4°-10°	6°-18°

Check the superheat and select correct subcooling according to superheat, refer to "Final Subcooling table". It is recommended to keep the superheat at 10-18°F if a third party indoor unit is used.

Onboard Parameter Check & Diagnostics

1. Press “Check” button to index through parameters.
2. After first pressing on the “Check” button, it will display the sequence, and after 1 second it will display the value of the parameter.
3. After 20 seconds on same parameter, display will revert back to normal status.
4. If a system protection is active, first digit will display “status code.”

Figure 4.1

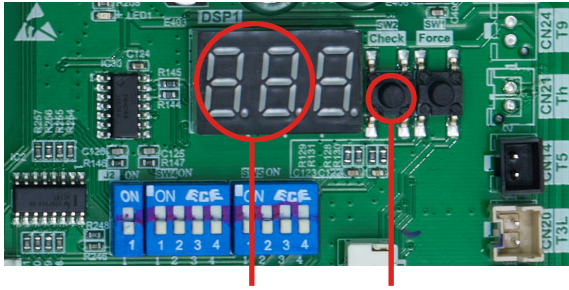

Control Board Display Check Mode Button

Manual/Force Defrost

1. System must have a call for heat and have been operating for a minimum of 8 minutes.
2. Press “FORCE” button on inverter board for 6 seconds to begin forced defrost.
3. Wait Approximately 40 seconds for defrost to initiate.
4. Once defrost initiates the display will indicate “dF”.
5. Defrost test will terminate automatically after which the display will indicate running speed.
6. Repeat steps after 5 minutes if second test is required.

Figure 4.4

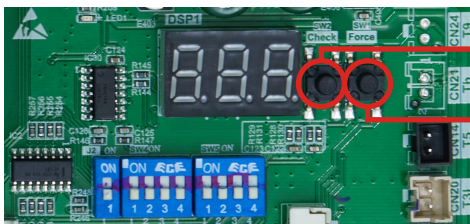

Check Mode Button
Force Button

System Protection Codes [Figure 4.5](#)

┆	Forced operation mode
L	Running indication under T3 limited condition
d	Running indication under T5 limited condition
P	Running indication under compressor ratio limited condition
F	Running indication under TF limited condition
C	Running indication under current limited condition
U	Running indication under low voltage limited condition
A	Running indication under return oil mode
dF	Running indication under defrost mode

CODE	FAULT DESCRIPTION
Atl	Ambient Temperature Limited (T4)
b1	Temperature sensor fault in Indoor Unit (T1)-ULTRA UNIT ONLY
b2	Temperature sensor fault in Indoor Unit (T2)
b3	R454B refrigerant Sensor hardware fault in Indoor Unit
b4	R454B refrigerant sensor communication (wiring) fault in Indoor Unit
b5	Communication fault between Indoor unit and Outdoor unit
b6	Power consumption sensor fault in indoor unit
b7	R454B refrigerant leakage protection in indoor unit
b8	R454B refrigerant sensor over service life in indoor unit
c3	The coil sensor is seated fault in cooling (T3)
E41	Temperature sensor fault (T3)
E42	Temperature sensor fault (T3L)
E43	Temperature sensor fault (T4)
E44	Temperature sensor fault (T5)
E45	Temperature sensor fault (Th)-PREMIUM & LIGHT UNIT ONLY
E46	Temperature sensor fault (T6A)-ULTRA UNIT ONLY
E47	Temperature sensor fault (T6B)-ULTRA UNIT ONLY
E48	Temperature sensor fault (T7)-ULTRA UNIT ONLY
E49	Baseplate heating fault-ULTRA UNIT ONLY
E51	Outdoor unit high/low input voltage
E52	Outdoor unit high/low DC bus voltage protection
E7	Compressor discharge sensor is seated fault (T5)
E81	EEVA coil fault
E82	EEVC coil fault-ULTRA UNIT ONLY
EA	Control program does not match drive program in outdoor unit
F1	High pressure switch fault (HPS)
F2*	5 Times (P2) protection in 100 minutes, system lockout
F4	Pressure transducer fault (PT)-LIGHT UNIT ONLY
F41	High pressure sensor fault-ULTRA & PREMIUM UNIT ONLY
F42	Low pressure sensor fault-ULTRA & PREMIUM UNIT ONLY
H01	Drive chip communication fault in outdoor unit
H04	Power consumption sensor communication fault in outdoor unit-ULTRA UNIT ONLY
H14	Power consumption sensor fault in outdoor unit-ULTRA UNIT ONLY
J00-JCF	Compressor drive fault
n00-nCF	Outdoor fan motor driver fault
P0	Compressor IPM temperature protection
P1	High pressure switch protection (HPS)
P11	High pressure protection in cooling/heating (Pc)
P21	Low pressure protection in cooling/heating (Pe)
P31	Outdoor init input over current protection
P32	Compressor over current protection
P4	High compressor discharge temperature protection (T5)
P5	Condenser coil temperature protection in cooling (T3)
Pb1	Hyper-Link (M1 M2) over current protection -ULTRA UNIT ONLY
PH	Low discharge superheat protection

Control Board & Dip Switch Functions

In most scenarios, it is recommended to keep all outdoor unit board dip switch positions in their manufacturer default positions. There are some specific scenarios when it makes sense to change dip switch settings.

Dip Switch SW4

SW4-1 and SW4-2 are not used and should remain in the factory default position at all times. SW4-3 and SW4-4 give you coil temperature and modulation control.

SW4-3 Function

Default is OFF position (enabled), allows for coil/condenser target temperature to drift +/- 4°F based on previous hour of operation in an attempt to optimize run time. If dip switch is changed to ON, software requires a “hard” target for coil temperature and does not drift to optimize runtime. **Reason to change from default:** In zoning Applications but only as needed as a result of customer expectations and/or performance.

SW4-4 Function

Default is OFF position, system uses the default target coil temperatures. If dip switch is changed to ON, reduces target coil temperature by 4°F in cooling and increases target coil temperature by 4°F in heating. **Reason to change from default:** Recommended to be used only as-needed as a result of customer expectations and/or performance (i.e. not getting enough capacity, or not dehumidifying well enough).

SW5-1 Function

Default is OFF position, uses default defrost operating time (maximum of 8 minutes). If dip switch is changed to ON, the default operating time before a unit goes into defrost is reduced by 10%. **Reason to change from default:** Can be used in colder climates to have the unit go into defrost more often.

Dip Switch SW5

Demand Defrost Adjustments

Defrosting Choice	SW5-1	SW5-2	Remarks
ON	Operating time is reduced by 10%	Defrosting extended for 60 seconds	
OFF	Normal	Normal	Default
Remarks	Enter defrost	Quit defrost	

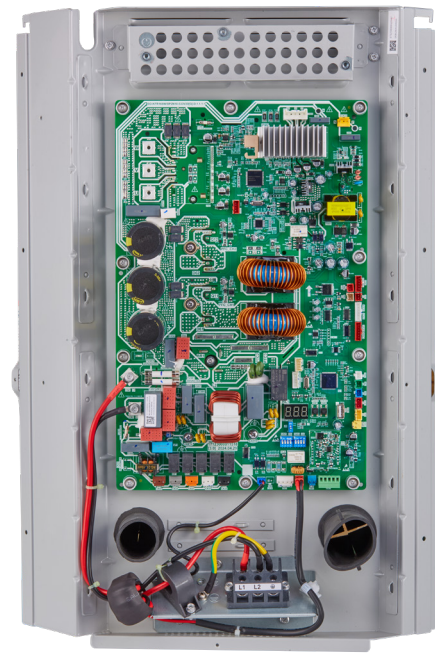

SW5-2 Function

Default is OFF position, uses default defrost operating time (maximum of 8 minutes). If change dip switch to ON, default defrost time is increased by 1 minute. **Reason to change from default:** Can be used in colder climates, where it make take more time than usual to defrost the outdoor coil.

J2 Function

Default is ON, which leaves the compressor capacity at default (3 or 5 ton depending on the model). Regardless of if the matching air handler is 2 ton or 3 ton (when paired with the 3 ton condenser), or matching air handler is 4 ton or 5 ton (when paired with 5 ton condenser), the J2 jumper can be left at default position. The compressor will ramp to required coil temperature regardless of paired air handler size. **Reason to change from default:** If you want (or need) to minimize maximum condenser capacity from 3 to 2 tons (3 ton condenser model) OR 5 to 4 tons (5 ton condenser model).

Communicating Dipswitches (SW7-1 & SW5-4)

Factory Default SW7-1 & SW5-4 is “ON” and must be turned “OFF” for non-communicating 24VAC connections.

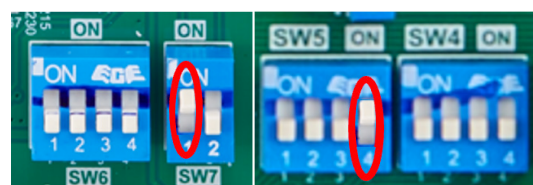

IDS Light & Plus (BOVA15) Control Board & Dip Switch Adjustments

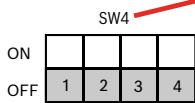
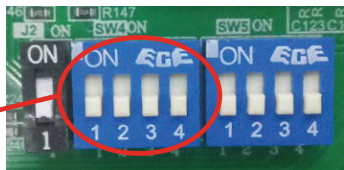

DIP Switch		Description
SW4-1	ON	Unused
	OFF	Must be set at "OFF" position
SW4-2	ON	Unused
	OFF	Must be set at "OFF" position
SW4-3	ON	Adaptive Capacity Output Disable
	OFF	Adaptive Capacity Output Enable*
SW4-4	ON	Accelerated Cooling/Heating
	OFF	Normal Cooling/Heating*

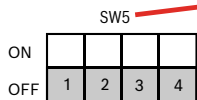
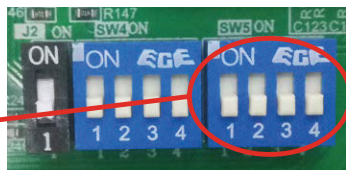

DIP Switch		Description
SW5-1	ON	Heating time reduced 10%
	OFF	Normal*
SW5-2	ON	Defrosting extended for 120 seconds
	OFF	Normal*
SW5-3	ON	Reserved
	OFF	Normal*
SW5-4	ON	Communication Mode
	OFF	Non-Communicating Mode

IDS LIGHT PARAMETER POINT CHECK TABLE			
NO.	POINT CHECK CONTENT	EXAMPLE	REMARK
0	Outdoor unit capacity	H5	H5=Heat Pump 5 ton
1	Outdoor unit mode	2	0 standby, 2 cooling, 3 heating
2	Outdoor unit set compressor speed	56	Hz
3	System last fault code	E4	System
4	T3: outdoor coil temp.(°F)	108	°F
5	T3L: outdoor coil outlet temp.(°F)	102	°F
6	T4: outdoor ambient temp.(°F)	95	°F
7	T5: compressor discharge temp.(°F)	140	°F
8	Tf: control board temp.(°F)	120	°F
9	Pe: evaporating pressure(psig) (only for cooling mode)	130	psig
10	Pc: condensing pressure(psig) (only for heating mode)	320	psig
11	Tes: target evaporating temp.(°F) (only for cooling mode)	43	°F
12	Te: evaporating temp.(°F)	43	°F
13	Tcs: target condensing temp.(°F) (only for heating mode)	106	°F
14	Tc: condensing temp.(°F)	106	°F
15	Target value of the compressor discharge superheat(°F) (only for heating mode)	36	°F
16	Compressor discharge superheat (°F)	36	°F
17	Openings of EEVA(P)	200	0-480P
18	Fan speed stage	8	(0-10)
19	Outdoor unit fan current(A)	1	A
20	Compressor current(A)	10	A
21	Outdoor unit input current(A)	10	A
22	Outdoor unit input voltage(V)	230	V
23	Outdoor unit DC bus voltage(V)	380	V
24	Outdoor unit power(*0.1kW)	200	Outdoor unit * 0.1kW
25	Continuous running time of the compressor(min)	35	minutes 0-999 Maintain at maximum
26	Outdoor unit main control software version	11	11
27	Indoor unit Heat Kit Staging (only for communication mode)	1	0~3
28	T2: indoor unit coil temp.(°F) (only for communication mode)	55	°F
29	Indoor unit software version (only for communication mode)	11	
30	Reserved	- -	
31	Remark "--"	- -	

IDS Premium (BOVA20) Control Board & Dip Switch Adjustments

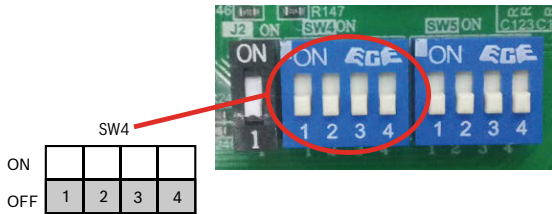

Switch	Description	
SW4-1	ON	Unused
	OFF	Must be set at "OFF" position
SW4-2	ON	Unused
	OFF	Must be set at "OFF" position
SW4-3	ON	Adaptive Capacity Output Disable
	OFF	Adaptive Capacity Output Enable*
SW4-4	ON	Accelerated Cooling/Heating
	OFF	Normal Cooling/Heating*

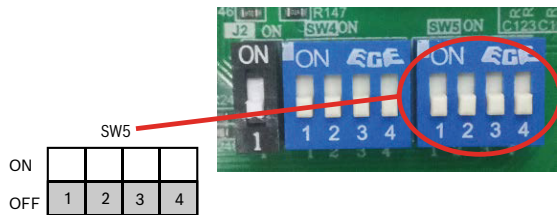

DIP Switch	Description	
SW5-1	ON	Heating time reduced 10%
	OFF	Normal*
SW5-2	ON	Defrosting extended for 60 seconds
	OFF	Normal*
SW5-3	ON	Reserved
	OFF	Normal*
SW5-4	ON	Communication mode
	OFF	Non-communicating mode*

IDS PREMIUM PARAMETER POINT CHECK TABLE			
NO.	POINT CHECK CONTENT	EXAMPLE	REMARK
0	Outdoor unit capacity: H5=Heat pump 5 ton	H5	H5=Heat Pump 5 ton
1	Outdoor unit mode: 0-standby, 2-cooling, 3-heating	2	0 standby, 2 cooling, 3 heating
2	Outdoor unit set compressor speed	56	Hz
3	System last fault code	E4	system
4	Liquid valve subcooling (°F)	10	°F
5	Gas valve superheat (°F)	10	°F
6	T3: outdoor coil temp.(°F)	108	°F
7	T3L: outdoor coil outlet temp.(°F)	102	°F
8	T4: outdoor ambient temp.(°F)	95	°F
9	T5: compressor discharge temp.(°F)	140	°F
10	Th: compressor suction temp.(°F)	55	°F
11	Compressor IPM temp.(°F)	120	°F
12	Pe: evaporating pressure(psig)	130	psig
13	Pc: condensing pressure(psig)	320	psig
14	Tes: target evaporating temp.(°F) (only for cooling mode)	43	°F
15	Te: evaporating temp.(°F)	43	°F
16	Tcs: target condensing temp.(°F) (only for heating mode)	106	°F
17	Tc: condensing temp.(°F)	106	°F
18	Target value of the compressor discharge superheat(°F) (only for heating mode)	36	°F
19	Compressor discharge superheat (°F)	36	°F
20	Compressor Suction superheat (°F)	10	°F
21	Openings of EEVA(P)	200	0-480P
22	Fan speed stage	8	(0-10)
23	Outdoor unit fan current(A)	1	A
24	Compressor current(A)	10	A
25	Outdoor unit input current(A)	10	A
26	Outdoor unit input voltage(V)	230	V
27	Outdoor unit DC bus voltage(V)	380	V
28	Outdoor unit power(*0.1kW)	200	Outdoor unit * 0.1 kW
29	Continuous running time of the compressor(min)	35	minutes/0-999/ Maintain at maximum
30	Outdoor unit main control software version	11	11
31	Indoor unit Heat Kit Staging	1	0~3
32	T2: indoor unit coil temp.(°F) (only for communication mode)	55	°F
33	Indoor unit software version(only for communication mode)	11	
34	reserved	--	--
35	Remark"--"	--	--

IDS ULTRA (BOVA19) Control Board & Dip Switch Adjustments

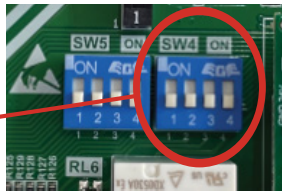

SW4	
ON	
OFF	

Switch	Description	
SW4-1	ON	Unused
	OFF*	Must be set at "OFF" position
SW4-2	ON	Accelerated cooling/heating 1
	OFF*	Normal cooling/heating
SW4-3	ON	Accelerated cooling/heating 2
	OFF*	Normal cooling/heating
SW4-4	ON	Adaptive capacity output disabled
	OFF*	Adaptive capacity output enabled



SW5	
ON	
OFF	

DIP Switch	Description	
SW5-1	ON	Heating time reduced 10%
	OFF	Normal *
SW5-2	ON	Defrosting extended for 60 seconds
	OFF	Normal *
SW5-3	ON	Unused
	OFF	Normal*
SW5-4	ON	Non-communicating mode
	OFF	Communicating Mode*

IDS ULTRA PARAMETER POINT CHECK TABLE			
NO.	POINT CHECK CONTENT	EXAMPLE	REMARK
0	Outdoor unit capacity: H5=Heat pump 5 ton	H5	H5=Heat Pump 5 ton
1	Outdoor unit mode: 0-standby, 2-cooling, 3-heating	2	0 standby, 2 cooling, 3 heating
2	Outdoor unit set compressor speed	56	Hz
3	System last fault code	E4	system
4	Liquid valve subcooling (°F)	10	°F
5	Gas valve superheat (°F)	10	°F
6	T3: outdoor coil temp.(°F)	108	°F
7	T3L: outdoor coil outlet temp.(°F)	102	°F
8	T4: outdoor ambient temp.(°F)	95	°F
9	T5: compressor discharge temp.(°F)	140	°F
10	Th: compressor suction temp.(°F)	55	°F
11	T7: outdoor outlet temp.(°F)	55	°F
12	T6A: injection inlet of the plate heat exchanger temp.(°F)	55	°F
13	T6B: injection outlet of the plate heat exchanger temp.(°F)	55	°F
14	Compressor IPM temp.(°F)	120	°F
15	Pe: evaporating pressure(psig)	130	psig
16	Pc: condensing pressure(psig)	320	psig
17	Tes: target evaporating temp.(°F) (only for cooling mode)	43	°F
18	Te: evaporating temp.(°F)	43	°F
19	Tcs: target condensing temp.(°F) (only for heating mode)	106	°F
20	Tc: condensing temp.(°F)	106	°F
21	Target value of the compressor discharge superheat(°F) (only for heating mode)	36	°F
22	Compressor discharge superheat (°F)	36	°F
23	Compressor Suction superheat (°F)	10	°F
24	Openings of EEVA(P)	200	0-480P
25	Openings of EEVC(P)	200	0-480P
26	Fan speed stage	8	(0-10)
27	Outdoor unit fan current(A)	1	A
28	Compressor current(A)	10	A
29	Outdoor unit input current(A)	10	A
30	Outdoor unit input voltage(V)	230	V
31	Outdoor unit DC bus voltage(V)	380	V
32	Outdoor unit power(*0.1kW)	200	Outdoor unit * 0.1 kW mintes/0-999/ Maintain at maximum
33	Continuous running time of the compressor(min)	35	
34	Outdoor unit main control software version	11	11
35	Indoor unit motor power(W)(only for communication mode)	300	W
36	Indoor unit Heat Kit Staging	1	0~3
37	T1: Indoor unit ambient temp.(°F) (only for communication mode)	55	°F
38	T2: indoor unit coil temp.(°F) (only for communication mode)	55	°F
39	Indoor unit software version(only for communication mode)	11	
40	Demand Response Setting	1	1~3
41	reserved	--	--
42	Remark "--"	--	--

Bosch EasyAir App



Troubleshooting
Made Easy!



The Bosch EasyAir App is your one-stop shop for troubleshooting the IDS Premium Connected. With just a few swipes on your phone, you can easily access information about installation, warranty registration, and how to monitor the unit remotely.



Remote Monitoring & Troubleshooting

Monitor the heat pump's health and visualize real time alerts remotely. View fault codes, live check point values and calculate superheat and subcool values that will help in troubleshooting faults quickly.



Get Notified on System Faults

Receive alerts on your phone right away about unit errors, warnings, and other important updates.



Manage Your Technicians

As the owner of the company or an office admin that dispatches technicians, you can add installers/technicians to your company profile and manage which homeowner units they can access.



Warranty Registration

Quickly and efficiently register products for warranty at the click of a button in the EasyAir App.

Connected Features Bosch EasyAir Mobile App

The Bosch Premium Connected and Ultra condenser features wireless connectivity and allows the contractor to access information about warranty registration, installation, and troubleshooting via the Bosch EasyAir App.

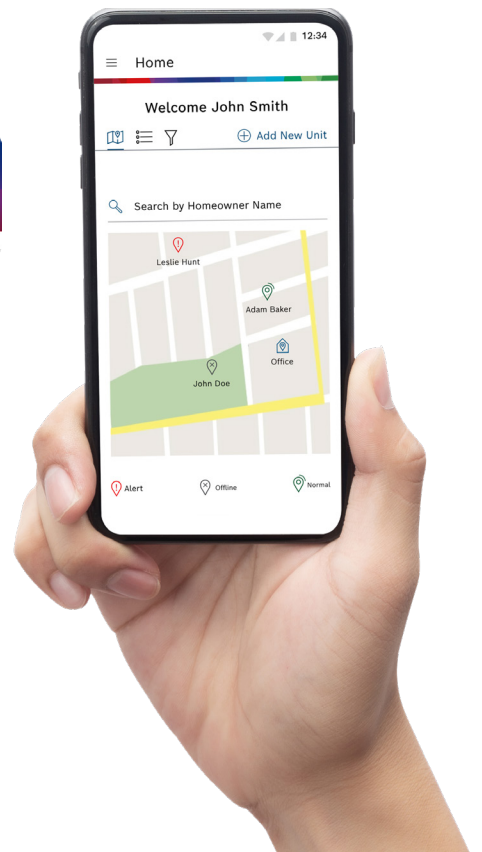

To utilize all the connected features of the Bosch ODU ensure the following:

1. The antenna has been mounted as instructed.
2. The Bosch EasyAir App has been downloaded on your smartphone.
3. The condenser has been added to the Bosch EasyAir App.
4. The condenser is linked to the homeowner and access to monitor the condenser remotely has been granted.

Mounting Antenna

The antenna is used to transmit data to the cloud and will have the strongest signal strength mounted furthest away from a wall or building.

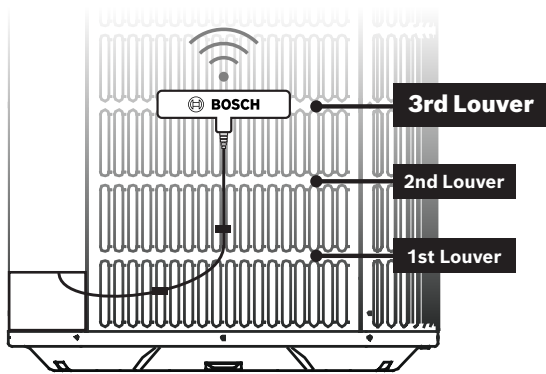

Mount the antenna on the 3rd Louver from the bottom of the unit.

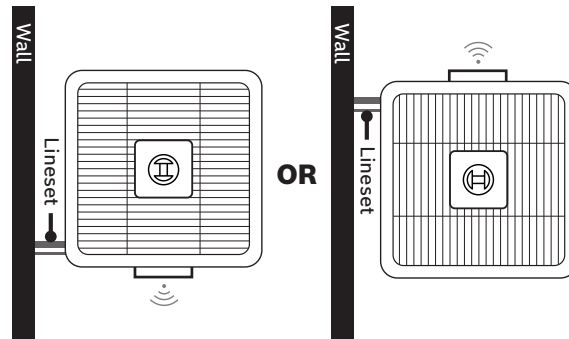

For the strongest signal mount the antenna on the side furthest from a wall on the left or right side of the unit.

Downloading the Bosch EasyAir App

1. Download the Bosch EasyAir App on your smartphone by searching for it in Google Play Store (for Android devices) or App Store (for iPhone). Alternatively, you can scan this QR code with your phone's camera.
2. Open the Bosch EasyAir App and create a profile.

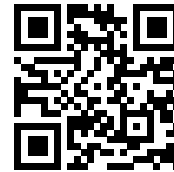

Scan QR with Smartphone to Download App

Adding the Condenser to the Bosch EasyAir App

Open the Bosch EasyAir App, From the 'Home' Screen click on the "Add New Unit" button and follow instructions on the App.

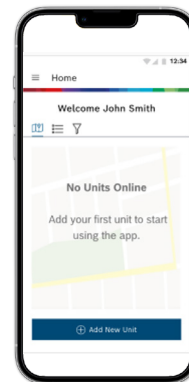

Connecting to the Bosch Premium Connected (BOVB20) Condenser

1. Ensure the unit is powered on.
2. Once the unit is powered on, wait until the gateway has a solid green and amber LED.
3. Launch the Bosch EasyAir App and connect to the unit via Bluetooth.
4. Access the Unit Dashboard to install, troubleshoot and register warranty more efficiently.

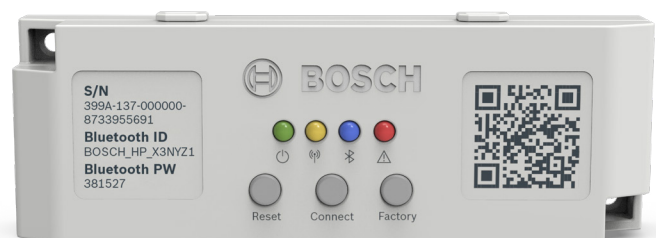

Communicating Wiring Diagrams

IDS Light Communicating

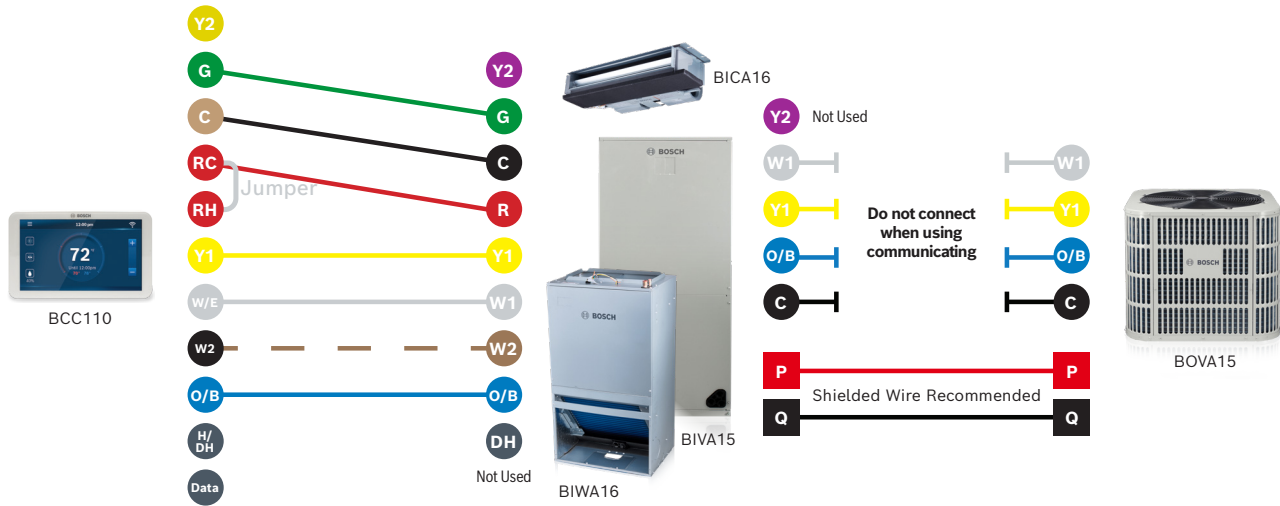

IDS Plus/Premium Communicating

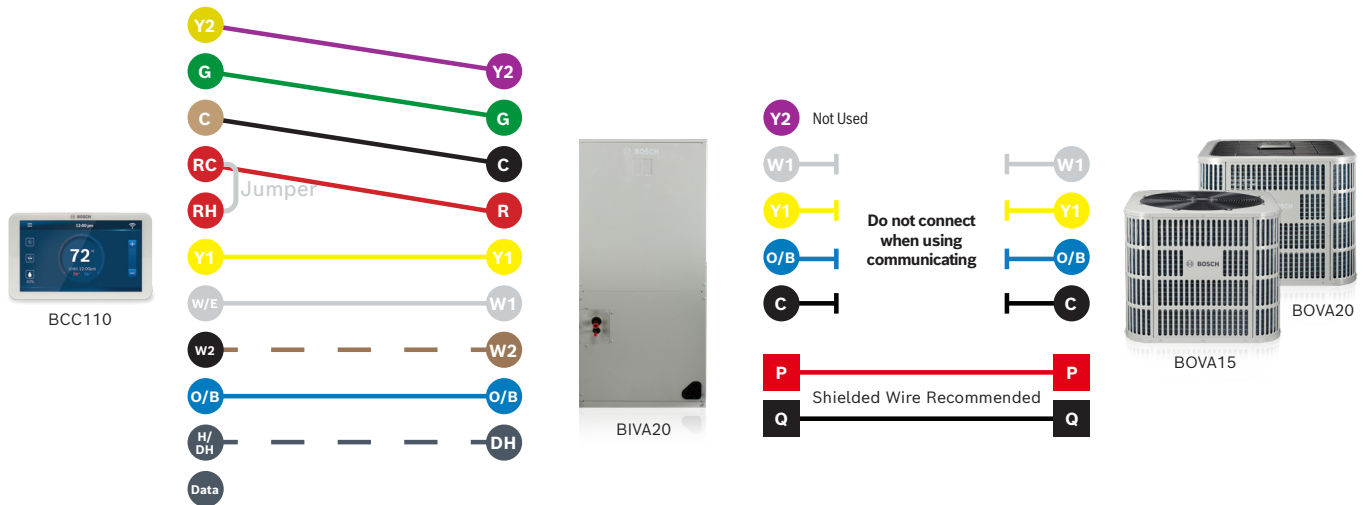

IDS Ultra Communicating

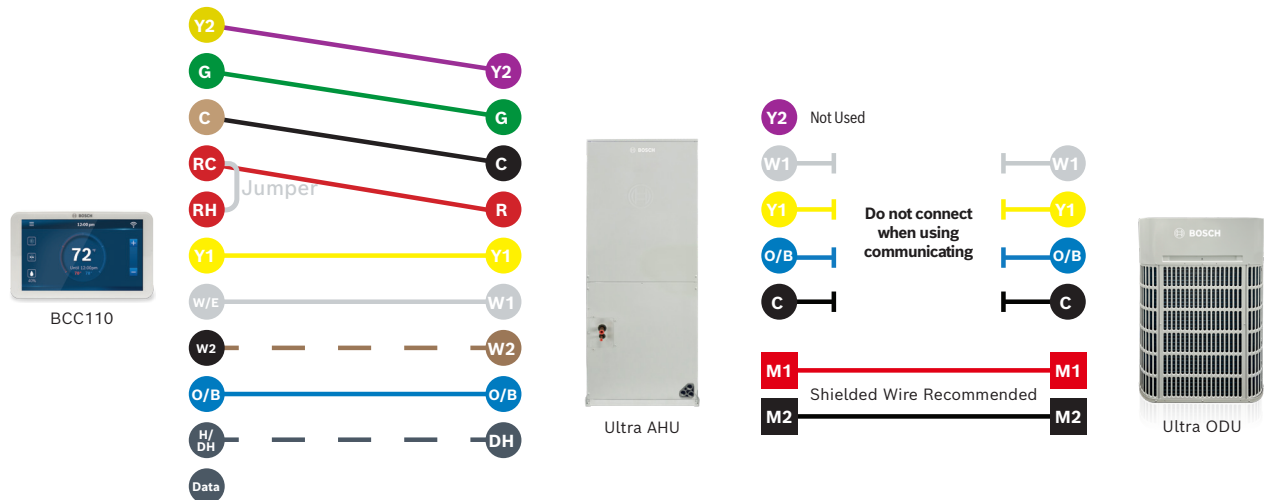

Non-Communicating Wiring Diagrams

IDS Light Non-Communicating

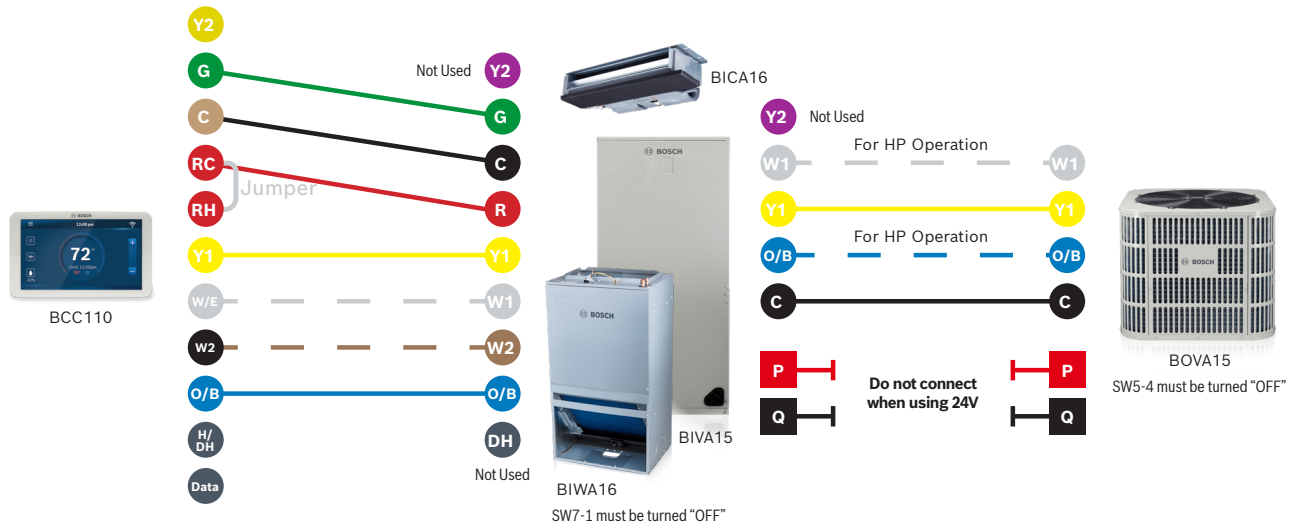

IDS Plus/Premium Non-Communicating

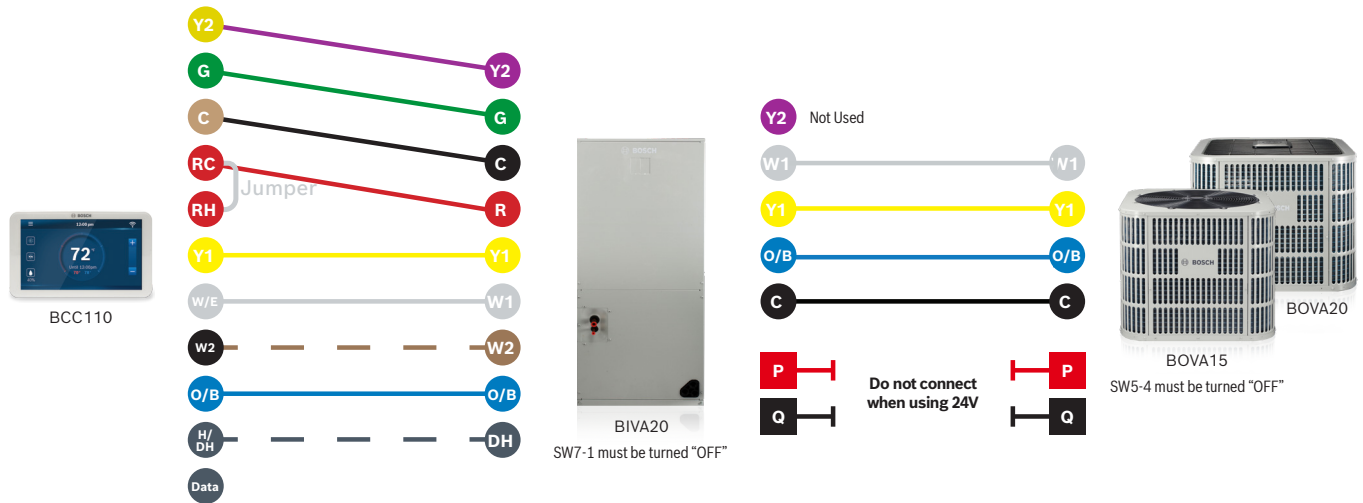

IDS Ultra Non-Communicating

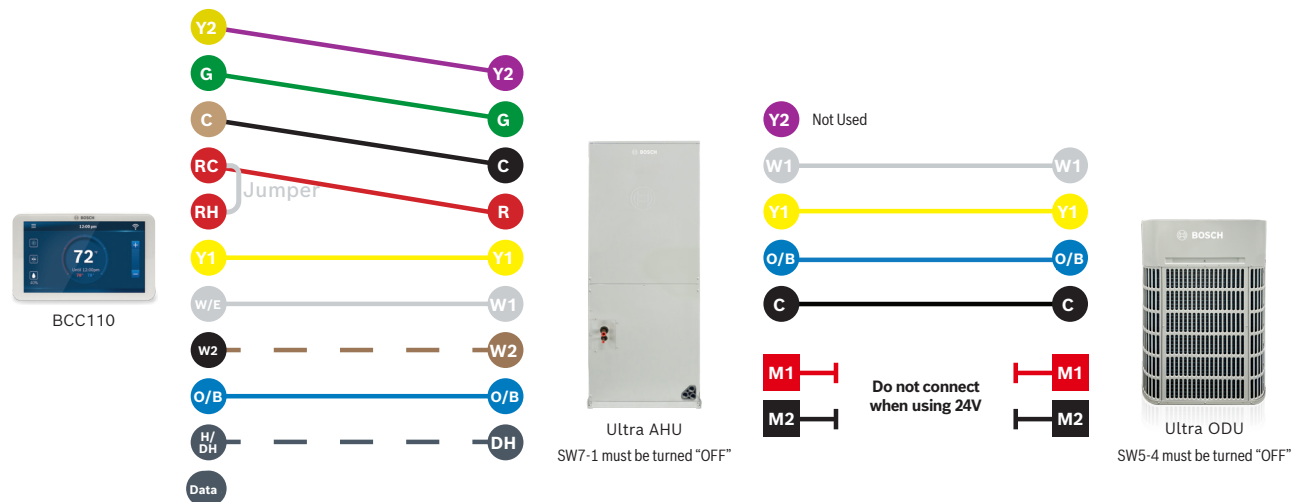

Communicating w/Furnace

IDS with Furnace or MBX Modular Blower

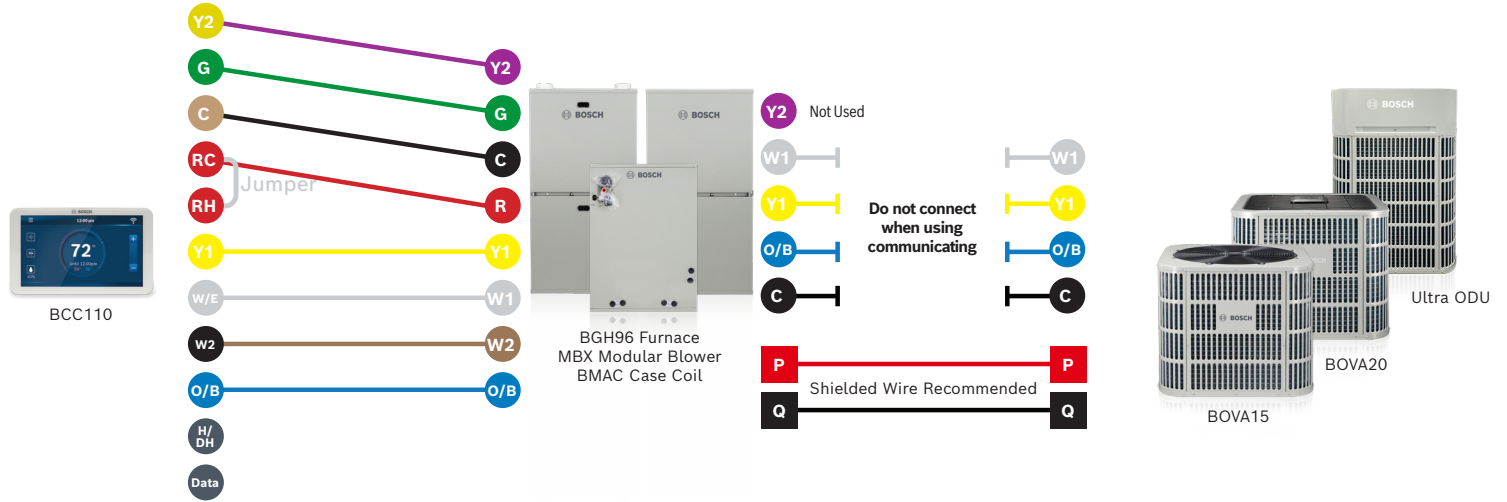

Wiring and Control Logic (A2L Box)

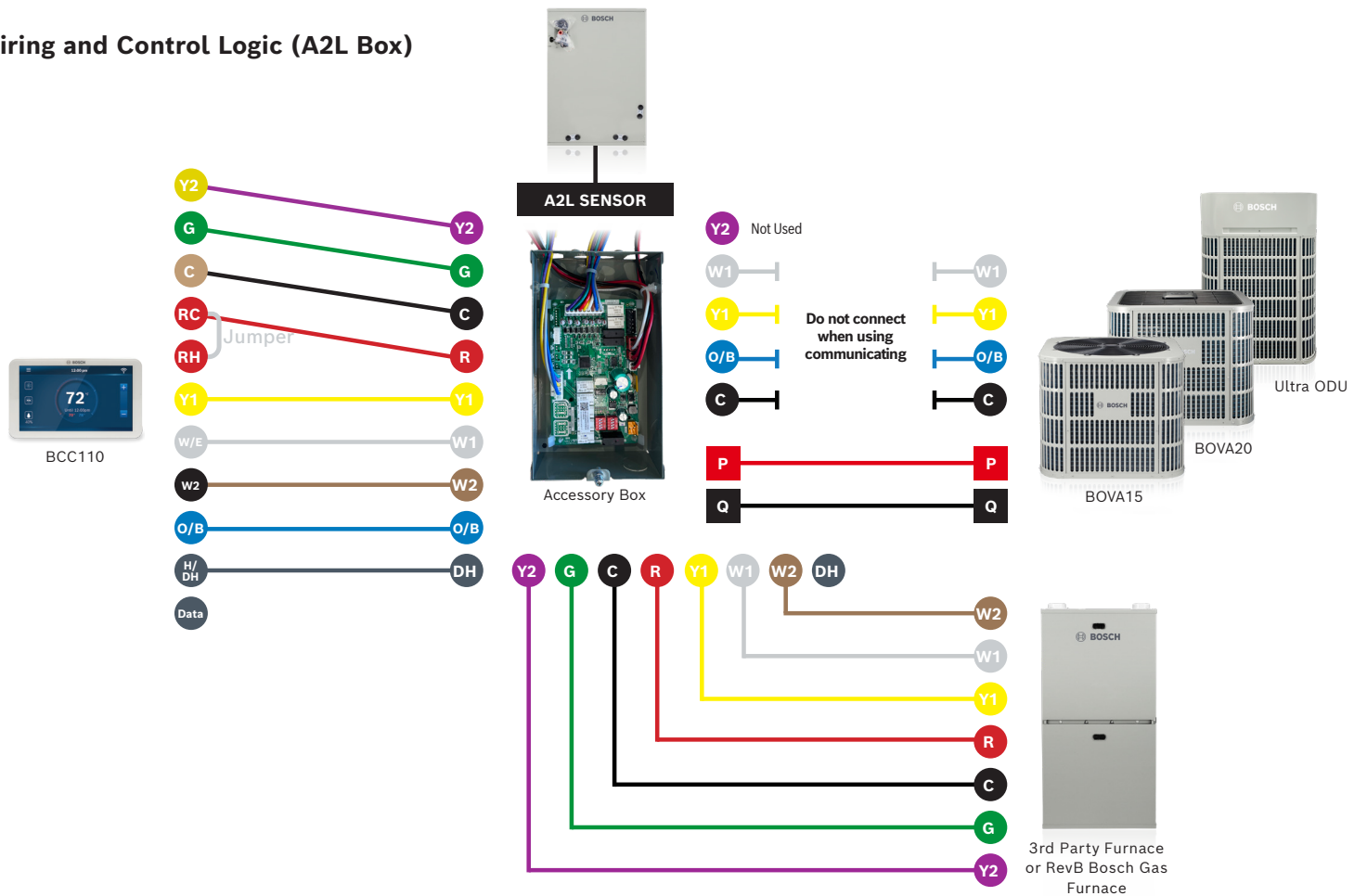

Non-Communicating w/ Furnace

IDS with Furnace or MBX Modular Blower

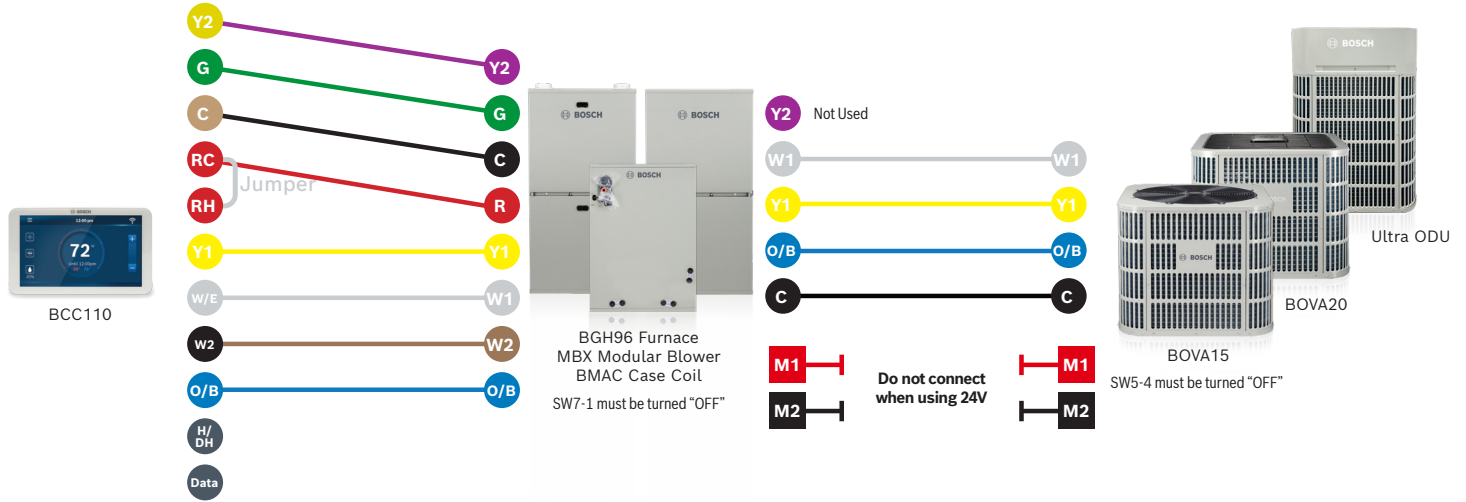

Wiring and Control Logic (A2L Box)

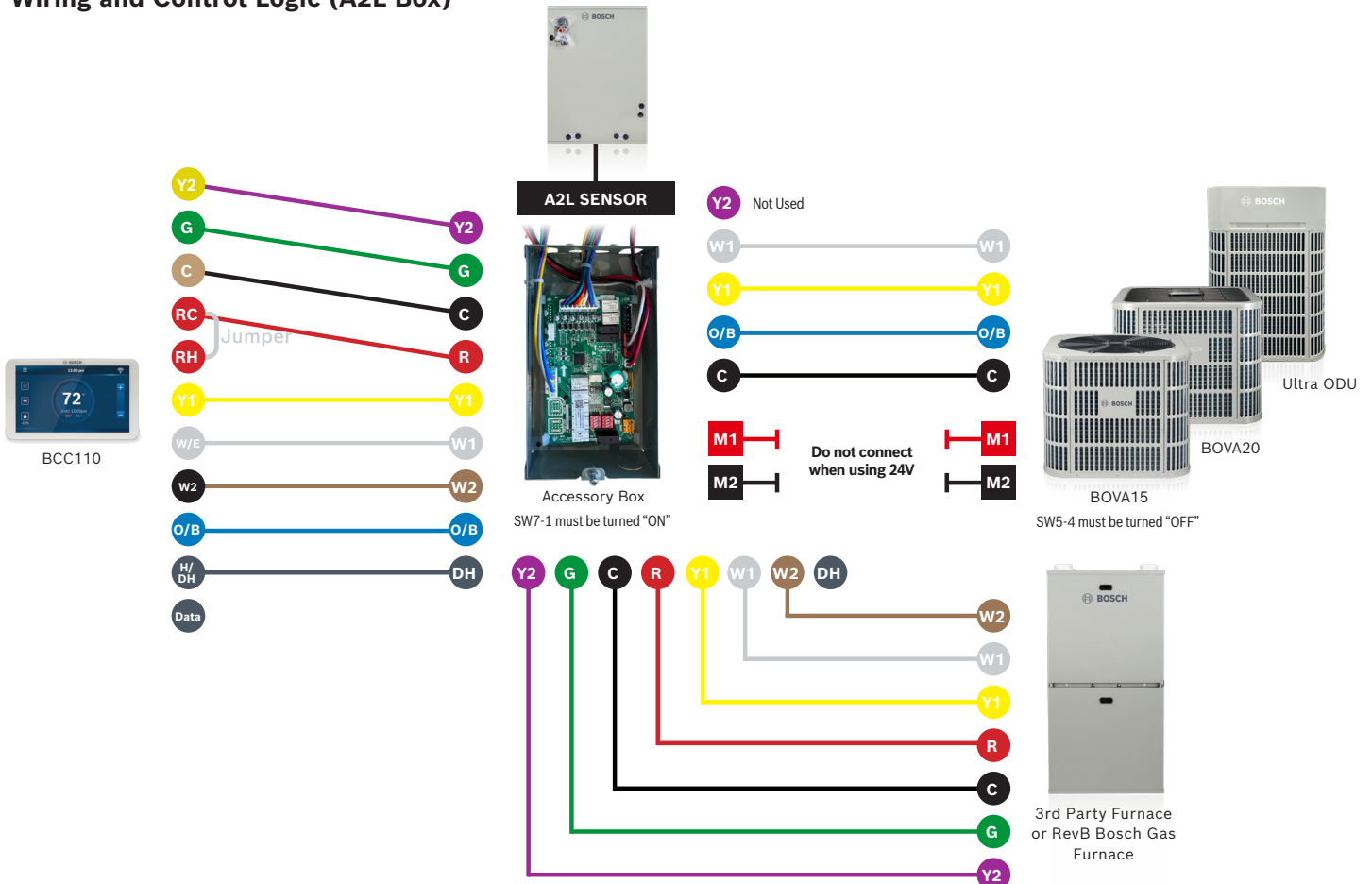

Bosch BGH96 Gas Furnace

Pair the Bosch BGH96 Gas Furnace with the Bosch IDS Family for the ultimate dual fuel solution. In the warmer months, the IDS inverter heat pump delivers whisper-quiet, energy-efficient cooling and dehumidification. When temperatures drop, the BGH96 seamlessly takes over, providing powerful and efficient heating, ensuring homeowners enjoy year-round comfort without compromise.



Airflow Adjustment

Equipped with an EON ECM circulator blower motor which provides ease in adjusting blower speeds

Blower speeds should be adjusted by the installer to match the installation requirements to provide the correct heating temperature rise and the correct cooling CFM.

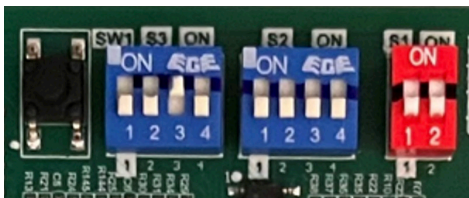

Adaptor Box Wiring Logic

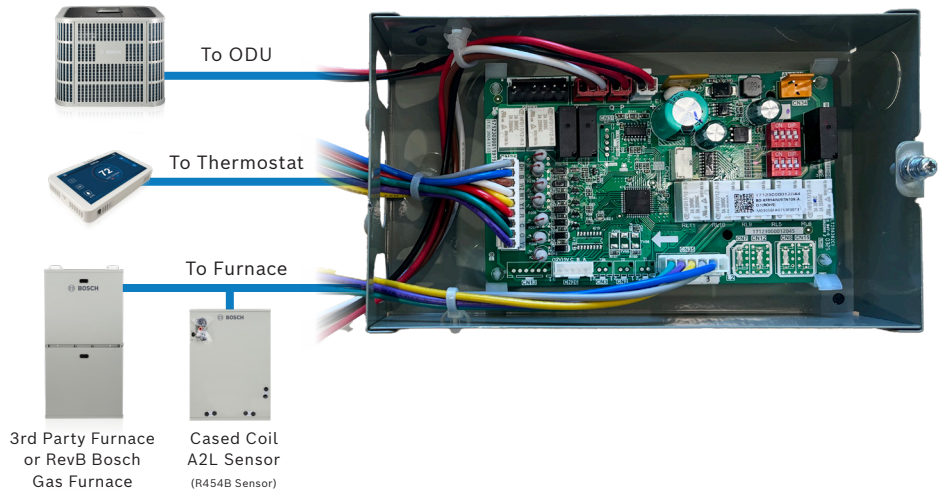

W2 DELAY		
DIP SW		NOMINAL (MINS)
S1-1	S1-2	
*OFF	OFF	OFF
ON	OFF	10
OFF	ON	AUTO
ON	ON	20

COOL OFF DELAY		
DIP SW		NOMINAL (SECS)
S2-3	S2-4	
*OFF	OFF	60
ON	OFF	90
OFF	ON	120
ON	ON	150

HEAT OFF DELAY		
DIP SW		NOMINAL (SECS)
S2-1	S2-2	
*OFF	OFF	90
ON	OFF	120
OFF	ON	150
ON	ON	180

MODEL	DIP SW			HI COOL	LOW COOL	HI HEAT	LOW HEAT
	S3-1	S3-2	S3-3				
60B	OFF*	ON	ON	High(5)	Mid(3)	Mid-H(4)	Mid(3)
	OFF	ON	OFF	Mid(3)	Mid-L(2)	Mid-H(4)	Mid(3)
80B	ON*	OFF	OFF	High(5)	Mid-H(4)	High(5)	Mid(3)
	ON	ON	ON	Mid(3)	Mid-L(2)	High(5)	Mid(3)
	ON	OFF	ON	High(5)	Mid(3)	High(5)	Mid(3)
80C	ON	ON	OFF	Mid-H(4)	Mid(3)	High(5)	Mid(3)
	ON*	OFF	OFF	High(5)	Mid-H(4)	High(5)	Mid(3)
100C	ON	ON	OFF	Mid-H(4)	Mid(3)	High(5)	Mid(3)
	OFF	OFF	ON	Mid(3)	Mid-L(2)	Mid-H(4)	Mid-L(2)
100D	OFF	OFF	OFF	Mid-L(2)	Mid-L(2)	Mid-H(4)	Mid-L(2)
	OFF*	OFF	ON	Mid(3)	Mid-L(2)	Mid-H(4)	Mid-L(2)
120D	OFF*	ON	OFF	Mid(3)	Mid-L(2)	Mid-H(4)	Mid(3)

Bosch IDS

Cooling Today, Heating Tomorrow with Just One Wire



A Heat Pump System That Works Like A/C Right Out of the Box

Used to installing straight cooling systems? Out of the box, the Bosch Inverter Ducted Split (IDS) system operates as a cooling-only unit. That means you can install this heat pump just like any standard A/C system, using only two wires. When the homeowner is ready to turn on the heat, you can enable heating simply by energizing the O/B wire, adding a heat pump thermostat, and 1-2 additional low voltage conductors.



Scan to watch
See it in Action

How This Setup Works:

- ▶ **Installs like A/C:** Ships in cooling-only mode for familiar installs
- ▶ **Heat is built-in:** Just one wire needed to unlock it
- ▶ **No special thermostat required:** Compatible with OEM and standard Heat Pump thermostats (e.g., Bosch BCC110) as well as **1 heat 1 cool** non-communicating thermostats
- ▶ **Perfect for hot regions with mild winters**
- ▶ **Electric heat option available:** Connect W1/W2 if using Bosch heat strip kits
- ▶ **Futureproofs your install:** Add heating later without changing equipment

IDS A/C Only with BCC110

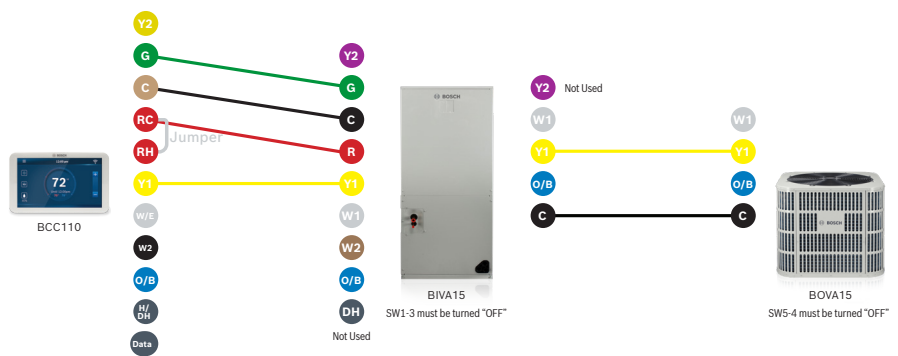

IDS A/C Only with Electric Heat Backup

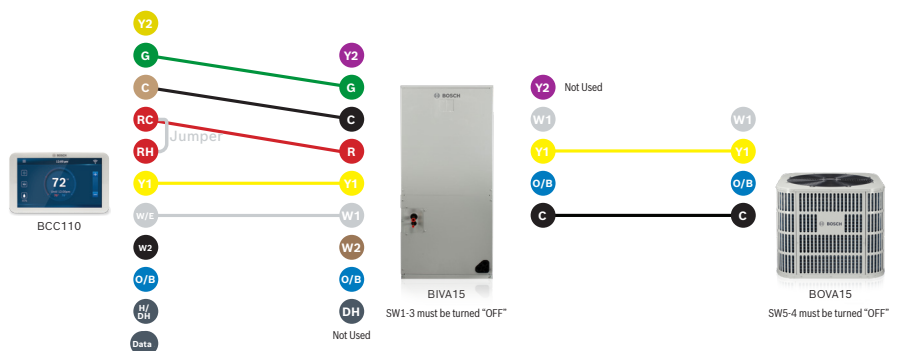

Service & Support Resource

- ▶ Manuals & Videos
- ▶ Product Specs.
- ▶ Technical FAQs
- ▶ Plus Much More
- ▶ Service Bulletins



You have arrived at your customer's location to work on their Bosch equipment.

Forgot what that error code means? Where is the temperature sensor?

What scheduled maintenance is required? Where is the installation and service manual?

Your time is valuable, and information is priceless.

Find the answers and information you need quickly and easily with our Service & Support page!

Bosch Service & Support Page

bosch-homecomfort.us/service



Scan QR to access page

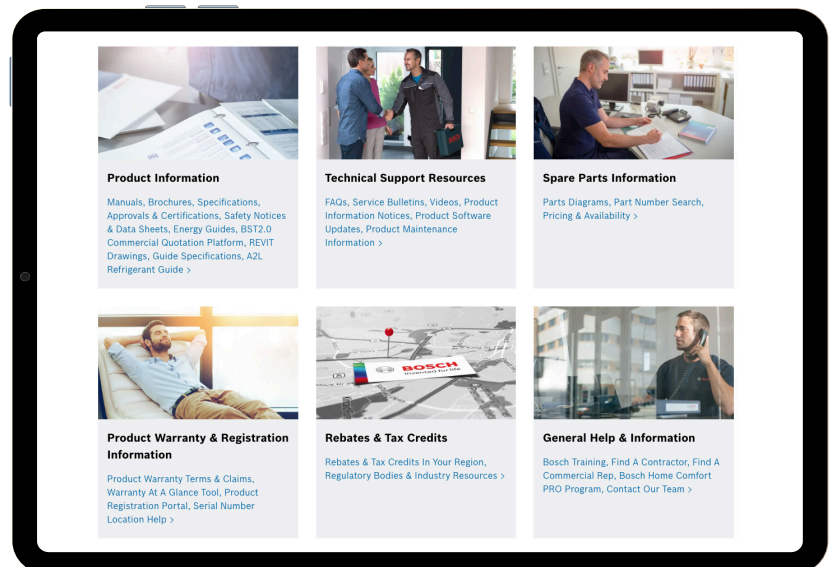

The Parts Information You Need Is Here

Find part numbers, price, availability, & warranty terms!



Spare Parts Finder

Search equipment by product series along with model number, material number, and serial number.

Warranty At-A-Glance

Find the specific warranty terms of your part by using the serial number search.

Price & Availability Tool

Search for your part and then click on the part number to see quantity on hand, location, and status.

Where Used

Enter a part number to find out what parent unit that component is used in.

Aftermarket Resource Center

arc.bosch-homecomfort.us



Scan to access the ARC home page



Scan for help with using the ARC tools

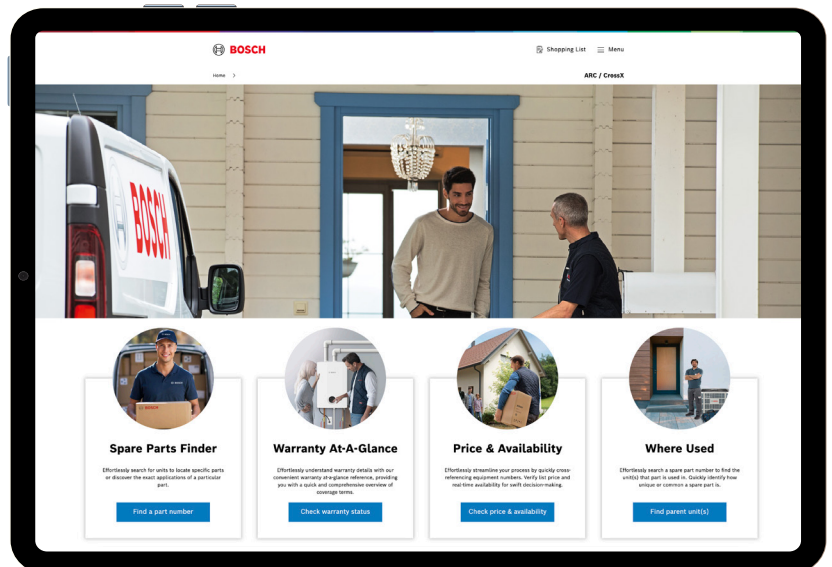

Built for Pros Powered by Bosch

Grow Your Business with Exclusive Tools,
Rewards & Support from Bosch.



BOSCH

Home Comfort PRO



Bosch is proud to offer contractors a powerful partnership through the Home Comfort PRO Program. Designed to help you grow, manage, and streamline your HVAC business, this FREE program gives you access to a world of benefits; marketing support, lead generation tools, product rewards, and more. Whether you're just getting started or looking to take your business to the next level, Bosch is here to help you succeed. Join now and get rewarded for doing what you already do best.

By choosing Bosch, you represent one of the largest HVAC brands in the market with over 100 years of industry expertise. Join our team of Professional dealers to gain access to rewards, exclusive sales and marketing tools, technical support, and more.

Register for your FREE Account!

Join the Bosch Home Comfort Program Today!



URL: scnv.io/NfCc



Earn Points for Every Product Registration

Redeem for Bosch gear, apparel, tools and gift cards!



Access the Bosch Partner Portal

Register products, track rewards, manage your business, and more—on the go.



Seamless Onboarding & Team Management

Easily set up your company profile, invite employees, and assign roles, all from one platform.



Get Found by New Customers

Qualify for Bosch's Installer Locator and Lead Management Tool.



Enjoy Extended Warranty & Priority Support

Platinum PROs earn a 1-year extended parts warranty on every registered install.



Join the Growth Rally Program

Hit your targets and watch your points multiply.



Bosch Marketing Collateral

Promote your business with downloadable assets and product images.



Track Tier Status & Business Performance

Silver, Gold, and Platinum levels with increasing rewards and visibility.



Sales, Service & Support, We are here to help!

Customer & Technical Support

Tel: 800-283-3787

Technical Support Hours: Mon-Fri, 8am - 7pm ET

Customer Support Hours: Mon-Thur, 8am-6pm ET

Customer Service E-mail Address

residential.salessupport@us.bosch.com

commercial.salessupport@us.bosch.com

Technical Support E-mail Addresses

AC: ac.techsupport@us.bosch.com

Furnace: furnace.techsupport@us.bosch.com

Boiler: boiler.techsupport@us.bosch.com

Tankless: tankless.techsupport@us.bosch.com

Parts Orders or Parts Inquiries E-mail Address

parts.salessupport@us.bosch.com

Warranty & Returns Support E-mail Address

warranty_returns@us.bosch.com

Addresses

65 Grove Street, Watertown, MA 02472

555 NW 65th Court, Fort Lauderdale, FL 33309

50 Wentworth Avenue, Londonderry, NH 03053

Contractor Website

bosch-homecomfort.com/us/pro

bosch-homecomfort.com/ca/pro

Social

youtube.com/boschheatingcooling

facebook.com/boschheatingcooling

instagram.com/boschhvac



Bosch Home Comfort Group

We invent sustainable heating, cooling and well-being solutions – for a smarter and better life.

About Bosch

Bosch Home Comfort Group in North America

Bosch Home Comfort Group is a leading source of high quality water heating and comfort systems. The company offers gas tankless, electric whole house and point-of-use water heaters, Bosch and Buderus floor-standing and wall mounted boilers, Bosch and FHP geothermal, water-source and air-source systems as well as controls and accessories for all product lines. Bosch Home Comfort is committed to being Simply Smart by offering products that work together as integrated systems that enhance quality of life in an ultra-efficient and environmentally friendly manner. For more information, visit bosch-homecomfort.us.

Bosch Group

The Bosch Group is a leading global supplier of technology and services in the areas of Automotive, Industrial Technology, Consumer Goods and Building Technology. The company was founded in Stuttgart, Germany, in 1886 and presently has more than 440 subsidiaries and is represented in over 150 countries.

In the U.S., Canada and Mexico, the Bosch Group manufactures and markets automotive original equipment and aftermarket solutions, industrial drives and control technology, power tools, security and communication systems, packaging technology, home comfort solutions, household appliances and software solutions. The Bosch Group's products and services are designed to improving quality of life by providing innovative and beneficial solutions. In this way, the company offers technology worldwide that is Invented for life. Additional information is available online at www.bosch.com



Bosch Home Comfort Group

Watertown, MA | Londonderry, NH | Ft. Lauderdale, FL

General Inquiries: 1-866-642-3198

Copyright © 2025 Bosch Home Comfort Group
All rights reserved. Subject to change without notice.

76HTT3002N 8-25

www.bosch-homecomfort.us