

TECHNICAL SPECIFICATIONS FOR MODEL EUHC

INDOOR COMPACT ELECTRIC UNIT HEATER



Table of Contents

Unit Sizes	2
Features	2
Factory-Installed Options	2
Field-Installed Options	2
Technical Data	3
Dimensions	4
Clearances	5
Weights	5
Unit Location	5
Mounting Height	6
Heater Throw and Cover	6
Certification	8
Installation Codes	8
Electrical Connections	8

In keeping with our policy of continuous product improvement, we reserve the right to alter, at any time, the design, construction, dimensions, weights, etc., of equipment information shown here.

TECHNICAL SPECIFICATIONS—CONTINUED

Unit Sizes

These units are available in six unit sizes based on heating capacity of 2,000–20,000 watts.

Features

- Voltage/phase options: 208/1, 208/3, 240/1, 240/3, 277/1, 480/3, and 600/3
- Painted galvanized-steel cabinet with two-tone black and white glossy, scratch-resistant paint scheme
- Adjustable mounting bracket assembly enables unit to be mounted at desired downward and lateral angle
- Fully-sheathed heating elements
- High-temperature and FAN ON limit switch control with automatic reset
- External terminal strip for 24V wiring
- 208V and 240V units in sizes 3, 5, 7, and 10 are field-adjustable to 3-phase electrical power to reduce amperage demand and operating expense
- Two unit sizes—3 and 5—approved for residential use

Factory-Installed Options

Option	Description
AK4	277/1/60 voltage (unit sizes 3, 5, 7, and 10)
AK7E	480/3/60 voltage (all unit sizes)
AK8E	600/3/60 voltage (unit sizes 7, 10, 15, and 20)
AK15	208/1/60 voltage (unit sizes 3, 5, 7, and 10, field-convertible from 1- to 3-phase)
AK20	208-240/3/60 voltage (unit sizes 15 and 20)
AK22	208-240/1/60 voltage (unit sizes 3 and 5 approved for residential use)
AK44	208-240/3/60 voltage (unit sizes 3, 5, 7, and 10, field-convertible from 1- to 3-phase)

Field-Installed Options

Option	Description
CL1	Single-stage low-voltage thermostat
CL31, CL32	Multiple unit control: option CL31 includes components for one control unit and one additional unit—option CL32 includes components for each additional non-control unit
CL83	Two-stage programmable thermostat
CL84	Two-stage smart thermostat
CL90	BACnet-capable thermostat
CM1	Locking cover for CL1 thermostat
CM1B	Locking cover for CL83 and CL84 thermostats
CN3F	Remote OCCUPIED/UNOCCUPIED switch in 2 × 4 box
CP3, CP17, CP21, CP23, CP41, CP43	Remote disconnect switch
IT18	Unit-mounted CL83 thermostat with mounting kit
JB3	Unit wiring kit, includes CL83 thermostat with 25-foot wire and disconnect switch with wiring harness

Technical Data

Parameter	Unit of Measure	Unit Size (kW)						
		3	5	7	10	15	20	
Heating capacity	kW	3	5	7.5	10	15	20	
		2.3*	3.8*	5.6*	7.5*	11.25*	15*	
	BTUh	10,236	17,060	25,590	34,120	51,180	68,240	
7,868*		13,000*	19,158*	25,590*	38,486*	51,180*		
Nominal kW	kW	3	5	7.5	10	15	20	
Actual kW					9.9		19.8	
Discharge air opening area	foot ²	0.66		1.59		1.59		
	meter ²	0.06		0.15		0.15		
Air volume	CFM	340		640		1160		
	CMH	578		1088		1972		
Air velocity	FPM	515		403		730		
	meter/second	48		37		68		
Discharge air temperature rise	°F	28	43	35	48	41	54	
	°C	16	24	20	27	23	30	
Fan motor size	HP	0.03		0.07				
Fan diameter	inch	10		12		16		
Fan motor speed	RPM	1550				1050		
Fan motor full load amps	208V unit	amp	0.27		0.45		0.49	
	240V unit		0.31		0.51		0.56	
	277V unit		0.25		0.43		0.45	
	480V unit		0.16		0.28		0.30	
	600V unit		—		—		0.30	
Sound level @ 10 feet	dBa	58		67		61	56	

*Derated 240V capacity available with option AK19, AK20, or AK44.

Parameter	Voltage	Voltage Option	Phase									
			1				3					
			Unit Size (kW)									
			3	5	7	10	3	5	7	10	15	20
Full Load Amps (FLA)	208	AK15	14.7	24.3	36.5	47.9	8.6	14.1	21.3	28.2	—	
	208*	AK19, AK44	11.1	18.3	27.2	36.5	6.5	10.7	15.8	21.1	—	
		AK20	—								31.8	41.9
	240	AK19, AK44	12.8	21.1	31.8	42.2	7.5	12.3	18.6	24.6	—	
		AK20	—								36.6	48.7
	277	AK4	11.1	18.3	27.4	36.5	—					
	480	AK7E	—				3.8	6.2	9.3	12.3	18.4	24.4
600	AK8E	—				—				14.8	19.6	
Minimum Circuit Amps (MCA)	208	AK15	14.8	24.4	36.6	48.0	8.7	14.2	21.4	28.3	—	
	208*	AK19, AK44	11.2	18.4	27.3	36.6	6.6	10.8	15.9	21.4	—	
		AK20	—								31.9	42.0
	240	AK19, AK44	13.2	21.2	31.9	42.3	7.6	12.4	18.7	24.7	—	
		AK20	—								36.8	48.8
	277	AK4	11.4	18.6	27.5	36.6	—					
	480	AK7E	—				3.8	6.2	9.4	12.4	18.4	24.5
600	AK8E	—				—				14.8	19.6	
Maximum Overcurrent Protection (MOP)	208	AK15	20.0	35.0	50.0	60.0	15.0	20.0	30.0	40.0	—	
	208*	AK19, AK44	15.0	25.0	35.0	50.0	15.0		20.0	30.0	—	
		AK20	—								40.0	55.0
	240	AK19, AK44	20.0	30.0	40.0	55.0	15.0	20.0	25.0	35.0	—	
		AK20	—								50.0	60.0
	277	AK4	15.0	25.0	35.0	50.0	—					
	480	AK7E	—				15.0			20.0	25.0	35.0
600	AK8E	—				—				20.0	25.0	

*With derated 240V capacity.

TECHNICAL SPECIFICATIONS—CONTINUED

Dimensions

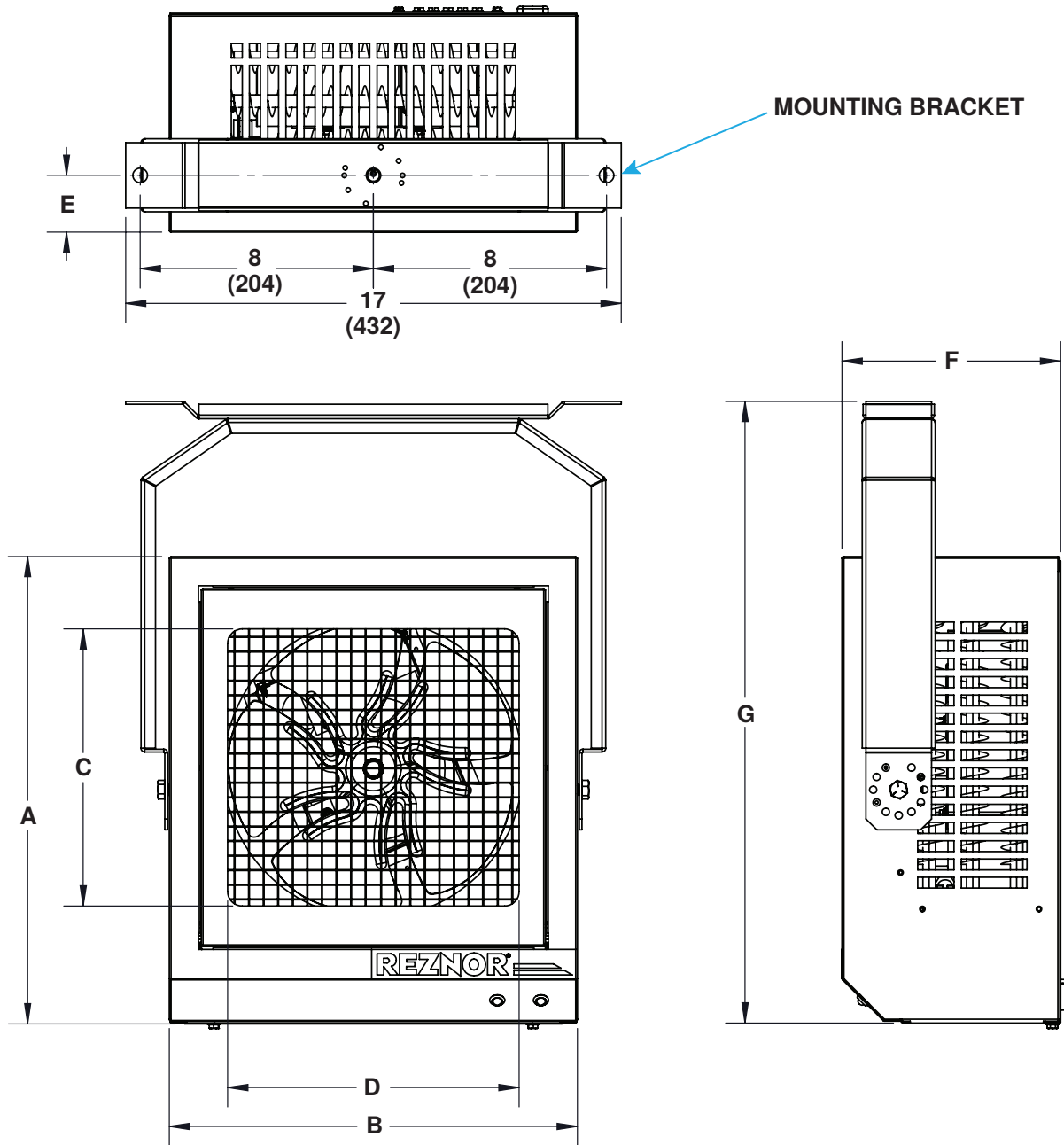

Cabinet Size	Unit Size (kW)	Dimension (See Graphic Above)						
		A	B	C	D	E	F	G
Inches (mm)								
1	3, 5	16-1/32 (408)	14 (356)	9-1/2 (242)	10 (254)	1-15/16 (50)	7 1/2 (191)	21-5/16 (542)
2	7, 10	21-3/4 (553)	19 (483)	15-1/4 (388)	15 (381)			27-1/16 (688)
3	15, 20	21-25/32 (554)	19-3/32 (485)			3-7/16 (88)	12-3/4 (324)	29-1/16 (739)

TECHNICAL SPECIFICATIONS—CONTINUED

Clearances

The unit must be located so that the clearances are provided for with regards to inspection and service and for proper spacing from combustible construction. Clearance to combustibles is defined as the minimum distance from the unit to a surface or object for which it is necessary to ensure that a surface temperature of 117°F (65°C) above the surrounding ambient temperature is not exceeded.

Unit Surface	Unit Size (kW)		
	3, 5	7, 10	15, 20
	Minimum Clearance (Inches (mm))		
Top (opposite controls side)	2 (51)		6 (153)
Back (non-discharge side)	7 (178)		8 (204)
Front (discharge side)	36 (915)		
Side (left and right)	4 (102)	6 (153)	9 (229)
Bottom (controls side)*	0 (0)		3 (77)

*Suspend the unit so that the bottom is a minimum of 6 feet (1.8 meters) above the floor.

Weights

Cabinet Size	Unit Size (kW)	Unit Weight	Shipping Weight
		Pounds (kg)	
1	3, 5	28 (13)	37 (17)
2	7, 10	40 (19)	53 (25)
3	15, 20	58 (27)	71 (33)

Unit Location

⚠ CAUTION ⚠

Do not locate the unit where it may be exposed to water spray, rain, or dripping water.

NOTE: This unit is for garage, workshop, or light industrial use only—it should never be used in a residential living space.

For best results, the unit should be located with certain rules in mind:

- Units should always be arranged to blow toward or along exposed wall surfaces, if possible. Where two or more units are installed in the same room, a general scheme of air circulation should be maintained for best results.
- Suspended heaters are most effective when located as close to the working zone as possible, and this fact should be kept in mind when determining the mounting heights to be used. However, care should be exercised to avoid directing the discharged air directly on the room occupants.
- Partitions, columns, counters, or other obstructions should be taken into consideration when locating the unit so that a minimum quantity of airflow will be deflected by such obstacles.
- When units are located in the center of the space to be heated, the air should be discharged toward the exposed walls. In large areas, units should be located to discharge air along exposed walls with extra units provided to discharge air in toward the center of the area.

TECHNICAL SPECIFICATIONS—CONTINUED

Mounting Height

⚠ WARNING ⚠

If touched, the internal surfaces that are accessible from outside the unit will cause burns. Suspend the unit a minimum of 6 feet (1.8 meters) above the floor.

In general, a unit should be located 6–14 feet (1.8–4.3 meters) above the floor. At those points where infiltration of cold air is excessive, such as at entrance doors and shipping doors, it is desirable to locate the unit so that it will discharge directly toward the source of cold air from a distance of 15–20 feet (4.6–6.1 meters).

Heater Throw and Cover

The graphic below shows throw and cover patterns and the table below lists throw and cover distances for heaters suspended at varying mounting heights and angles with either side discharge or down discharge. In the graphic and table below:

- H** = the distance from the bottom of the heater to the floor
- X** = the distance from the heater to the start of floor coverage
- Y** = the distance from the heater to the end of floor coverage
- Z** = the distance at which air velocity drops below 50 feet (15.2 meters) per minute
- D** = the diameter of floor coverage

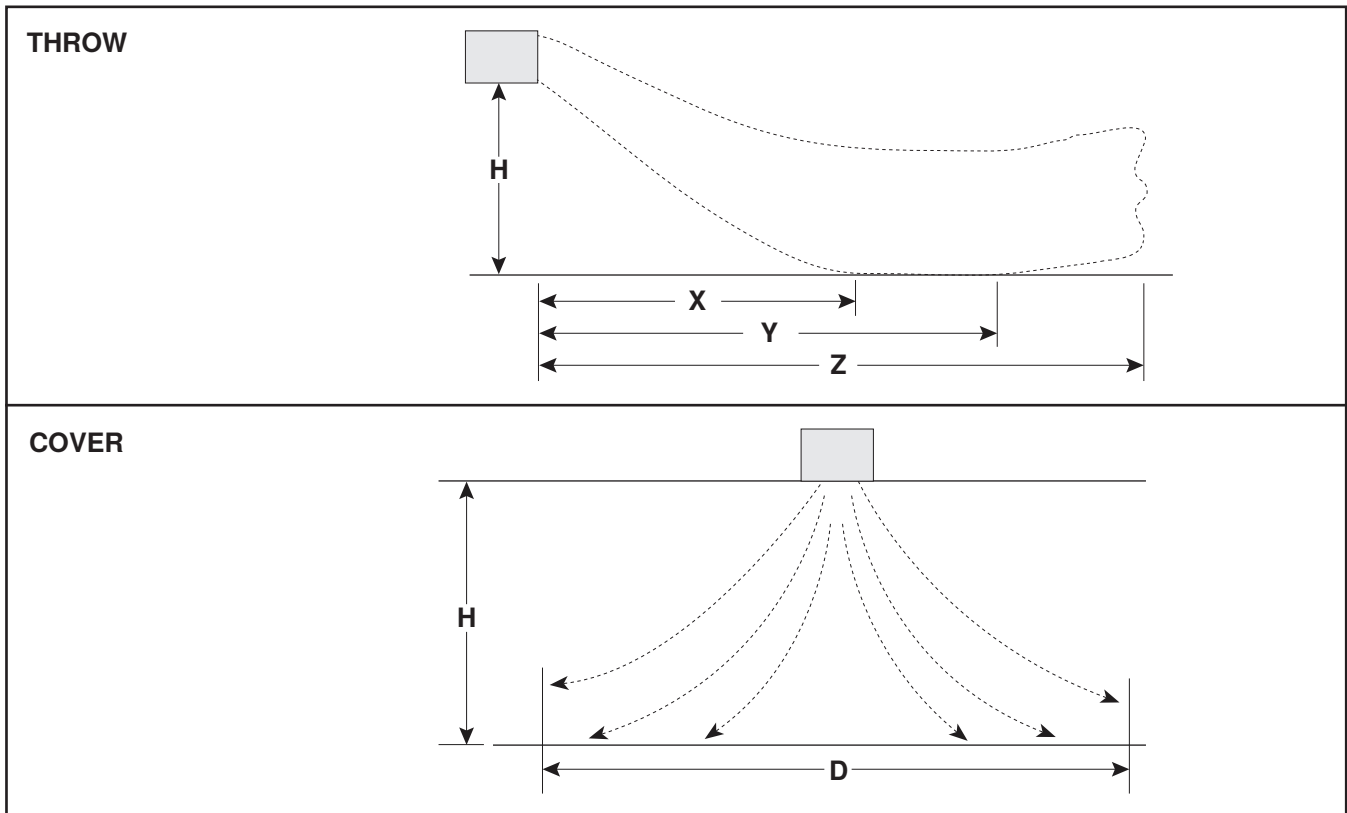

H* (Feet (Meters))	Mounting Angle (Degrees)	Dimension*	Unit Size (kW)					
			3	5	7	10	15	20
			Feet (Meters)					
6 (1.8)	45	X	6 (1.8)	5 (1.5)	5 (1.5)	5 (1.5)	5 (1.5)	5 (1.5)
		Y	16 (4.9)	16 (4.9)	22 (6.7)	18 (5.5)	23 (7.0)	25 (7.6)
		Z	24 (7.3)	25 (7.6)	33 (10.1)	33 (10.1)	40 (12.2)	38 (11.6)
7 (2.1)	45	X	9 (2.7)	7 (2.1)	6 (1.8)	7 (2.1)	6 (1.8)	6 (1.8)
		Y	11 (3.4)	18 (5.5)	22 (6.7)	20 (6.1)	23 (7.0)	24 (7.3)
		Z	23 (7.0)	26 (7.9)	33 (10.1)	34 (10.4)	40 (12.2)	38 (11.6)
8 (2.4)	45	X	—	9 (2.7)	7 (2.1)	10 (3.0)	7 (2.1)	6 (1.8)
		Y		16 (4.9)	22 (6.7)	22 (6.7)	23 (7.0)	23 (7.0)
		Z		25 (7.6)	34 (10.4)	35 (1.5)	42 (12.8)	39 (11.9)
	90	D	8 (2.4)	12 (3.7)	12 (3.7)	12 (3.7)	18 (5.5)	20 (6.1)
10 (3.0)	60	X	—	6 (1.8)	4 (1.2)	6 (1.8)	4 (1.2)	4 (1.2)
		Y		14 (4.3)	20 (6.1)	18 (5.5)	22 (6.7)	22 (6.7)
		Z		23 (7.0)	26 (7.9)	27 (8.2)	36 (11.0)	36 (11.0)
	90	D	8 (2.4)	10 (3.0)	13 (4.0)	14 (4.3)	16 (4.9)	18 (5.5)
12 (3.7)	60	X	—	8 (2.4)	6 (1.8)	10 (3.0)	6 (1.8)	5 (1.5)
		Y		12 (3.7)	18 (5.5)	14 (4.3)	22 (6.7)	22 (6.7)
		Z		22 (6.7)	28 (8.5)	25 (7.6)	38 (11.6)	37 (11.2)
	90	D	6 (1.8)	8 (2.4)	8 (2.4)	14 (4.3)	16 (4.9)	
14 (4.3)	60	X	—	10 (3.0)	10 (3.0)	7 (2.1)	6 (1.8)	
		Y		14 (4.3)	14 (4.3)	23 (7.0)	22 (6.7)	
		Z		26 (7.9)	25 (7.6)	38 (11.6)	35 (10.7)	
	90	D	6 (1.8)	6 (1.8)	12 (3.7)	14 (4.3)		
16 (4.9)	60	X	—	10 (3.0)	10 (3.0)	7 (2.1)	6 (1.8)	
		Y		22 (6.7)	23 (7.0)	23 (7.0)	22 (6.7)	
		Z		40 (12.2)	31 (9.4)	31 (9.4)	31 (9.4)	
	90	D	10 (3.0)	12 (3.7)	12 (3.7)	12 (3.7)		
18 (5.5)	60	X	—	12 (3.7)	12 (3.7)	12 (3.7)	12 (3.7)	
		Y		20 (6.1)	21 (6.4)	21 (6.4)	21 (6.4)	
		Z		38 (11.6)	30 (9.1)	30 (9.1)	30 (9.1)	
	90	D	8 (2.4)	10 (3.0)	10 (3.0)	10 (3.0)		

*See graphic above.

TECHNICAL SPECIFICATIONS—CONTINUED

Certification

⚠ DANGER ⚠

Heaters certified for residential use are intended for the heating of non-living spaces that are attached to or are part of a structure that contains space for family living quarters. They are not intended to be the primary source of heat in residential applications or to be used in sleeping quarters.

These units are listed by Intertek to UL 2021 and CSA C22.2 #46 for use in industrial and commercial installations in the US and Canada. In addition, unit sizes 3 and 5 with option AK22 are listed in the US and Canada as utility heaters for use in non-living spaces that are attached to, adjacent to, or part of a structure that contains space for family living quarters.

Installation Codes

This unit must be installed in accordance with local building codes. Local authorities having jurisdiction should be consulted before installation is made to verify local codes and installation procedure requirements.

Electrical Connections

⚠ CAUTION ⚠

- **Ensure that Ground Fault Overcurrent Protection (GFOC) and the Short Circuit Current Rating (SCCR) are adequate and provided for at the installation location.**
 - **Ensure that all wiring is in accordance with the wiring diagram provided with the unit.**
 - **All electrical wiring and connections, including electrical grounding **MUST BE** made in accordance with the *National Electric Code* (ANSI/NFPA No. 70, latest edition) or, in Canada, the *Canadian Electric Code* (Part 1, CSA C.22.1, latest edition). In addition, the installer should be aware of any local ordinances that might apply.**
 - **All external wiring **MUST BE** within approved conduit and have a minimum temperature rise rating of 140°F (60°C). Conduit must be run so as not to interfere with the access panel.**
-

NOTES

⚠ DANGER ⚠

- This unit has hot parts inside. Do not store or use gasoline or other flammable vapors and liquids in the vicinity of this or any other appliance.
- This unit is hot when in use. To avoid burns, do not let bare skin touch hot surfaces.
- Do not operate any unit after it malfunctions. Disconnect power at the service panel and have the unit inspected by a reputable electrician before reusing.
- Do not use outdoors.
- Do not insert or allow foreign objects to enter any unit opening as this may cause electrical shock, fire, or damage to the unit.
- To prevent a possible fire, do not block air intakes or exhaust in any way whatsoever.
- Use this unit only as recommended by the manufacturer. Any other use may cause electrical shock, fire, or damage to the unit.

For more information on Reznor HVAC products:

- Contact your local Reznor representative at 1-800-695-1901
- Refer to the manuals and additional consumer materials found at www.reznorhvac.com

