

H-7x70XLB - G-Series Magnetic Boiler Filter XL

H-7x70XLB Series

G-Series Magnetic Boiler Filter XL

12,000 Gauss Magnet
 Integrated Hose Drain Valve, Air Vent & Filter
 & Service Tool
 Requires (2) G-Union Fittings (Sold Separately)



Size (in)	Item#	Weight (lbs)	CTN Qty	Case Qty	A	B	C	145 PSI CWP Max	250°F Max
G-Thread 1 1/2"	H-70706	4.37	1	4	5.12	9.37	1.75		

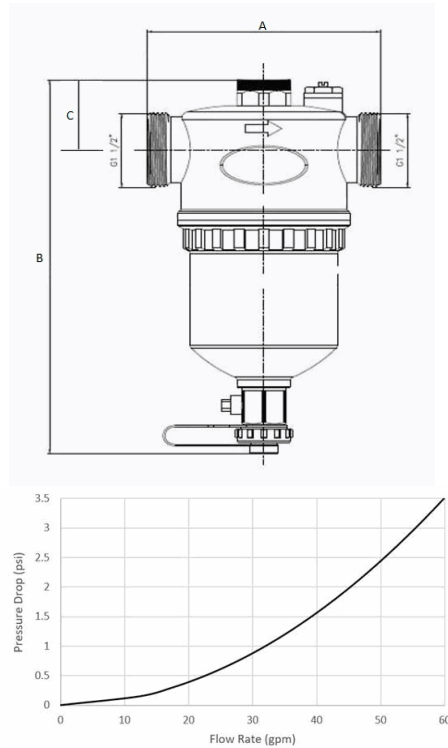
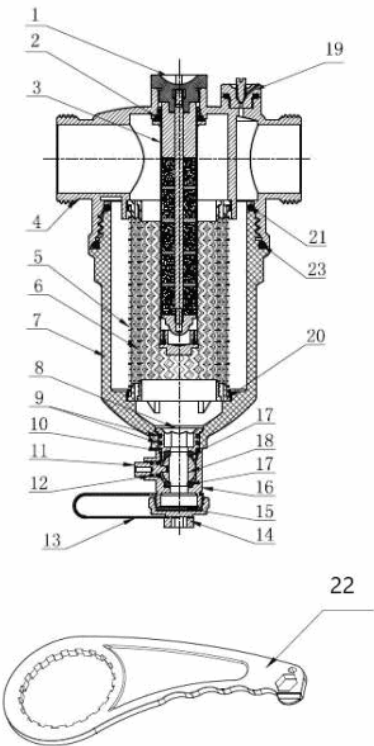

NO.	DESCRIPTION	MATERIAL
1	Magnet Bar	Various
2	O-ring	Rubber
3	Magnet Sleeve	Nickel Plated Brass
4	Body Upper Half	Brass
5	Outer Screen	Stainless Steel
6	Inner Screen	Stainless Steel
7	Body Lower Half	Plastic
8	Valve Cap	Brass
9	O-Ring	Rubber
10	O-Ring	Rubber
11	Valve Stem	Brass
12	O-Ring	Rubber
13	Strap	Rubber
14	Hose Cap	Brass
15	Gasket	Rubber
16	Valve Body	Brass
17	Valve Seat	Teflon
18	Valve Ball	Brass HCP
19	Vent Assembly	Various
20	Screen Guide	Plastic
21	O-Ring	Rubber
22	Service Tool	Plastic
23	O-Ring	Rubber

Specifications: Designed for use with water, oil, glycol mix in residential or commercial heating systems. Ensure 5.5" of clearance above the unit so that the magnetic bar may be removed for service. G-threaded bodies require matching G-union fitting for installation.

