

# D5FCFAH

## Installation Instructions

### Ceiling/Floor Unit Ductless System - Sizes 18K to 60K



Fig. 1 —Sizes 18K- 60K

**NOTES:** Read the entire instruction manual before starting the installation. Images are for illustration purposes only. Actual models may differ slightly.

### TABLE OF CONTENTS

	PAGE
.....	1
SAFETY CONSIDERATIONS .....	1
ELECTRICAL DATA .....	8
COMPATIBILITY .....	8
PRODUCT OVERVIEW .....	9
PART NAMES.....	9
PRODUCT INSTALLATION .....	10
WIRING DIAGRAMS.....	11
INSTALLATION SUMMARY .....	12
A. INSTALL INDOOR UNIT .....	13
B. INSTALL DRAIN PIPE.....	16
C. WIRING CONNECTION .....	17
INDOOR UNIT WIRING.....	18
D. CONNECT THE REFRIGERANT PIPES .....	18
TROUBLESHOOTING.....	20
DUCTLESS START - UP CHECKLIST - Single Zone.....	21

### SAFETY CONSIDERATIONS

Installing, starting up, and servicing air-conditioning equipment can be hazardous due to system pressures, electrical components, and equipment location (roofs, elevated structures, etc.). Only trained, qualified installers and service mechanics should install, start-up, and service this equipment.

Untrained personnel can perform basic maintenance functions such as coil cleaning. All other operations should be performed by trained service personnel only.

When working on the equipment, observe the precautions in the literature and on tags, stickers, and labels attached to the equipment.

Follow all safety codes. Wear safety glasses and work gloves. Keep a quenching cloth and a fire extinguisher nearby when brazing. Use care in handling, rigging, and setting bulky equipment.

Read these instructions thoroughly and follow all warnings or cautions included in the literature and attached to the unit. Consult local building codes and National Electrical Code (NEC) for special requirements. Recognize safety information.

This is the safety - alert symbol .

When you see this symbol on the unit and in instructions or manuals, be alert to the potential for personal injury. Understand these signal words: **DANGER**, **WARNING**, and **CAUTION**. These words are used with the safety- alert symbol.

**DANGER** identifies the most serious hazards which will result in severe personal injury or death.

**WARNING** signifies hazards which could result in personal injury or death.

**CAUTION** is used to identify unsafe practices which may result in minor personal injury or product and property damage.

**NOTE** is used to highlight suggestions which will result in enhanced installation, reliability, or operation.



## WARNING

### ELECTRICAL SHOCK HAZARD

Failure to follow this warning could result in personal injury or death.

Before installing, modifying, or servicing system, the main electrical disconnect switch must be in the OFF position. There may be more than 1 disconnect switch. Lock out and tag switch with a suitable warning label.



## WARNING



### EXPLOSION HAZARD

Failure to follow this warning could result in death, serious personal injury, and/or property damage.

Never use air or gases containing oxygen for leak testing or operating refrigerant compressors. Pressurized mixtures of air or gases containing oxygen can lead to an explosion.



## WARNING

Only use the specified wire. If the wire is damaged, it must be replaced by the manufacturer, its service agent or similarly qualified persons in order to avoid a hazard. The product must be properly grounded at the time of installation, or electric shock may occur.

For all electrical work, follow all local and national wiring standards, regulations, and the Installation Manual. Connect the cables tight, and clamp them securely to prevent external forces from damaging the terminal. Improper electrical connections can overheat and cause fire, and may also cause shock. All electrical connections must be made according to the Electrical Connection Diagram located on the panels of the indoor and outdoor units.

All wiring must be properly arranged to ensure that the control board cover can close properly. If the control board cover is not closed properly, it can lead to corrosion and cause the connection points on the terminal to heat up, catch fire, or cause electrical shock.

Disconnection must be incorporated in the fixed wiring in accordance with NEC, CSA and Local Codes. **Do not** share the electrical outlet with other appliances. Improper or insufficient power supply can cause fire or electric shock.

If connecting power to fixed wiring, an all-pole disconnection device which has at least 3mm clearances in all poles, and have a leakage current that may exceed 10mA, the residual current device (RCD) having a rated residual operating current not exceeding 30mA, and disconnection must be incorporated in the fixed wiring in accordance with NEC, CSA and Local Codes.



## CAUTION

### EQUIPMENT DAMAGE HAZARD

Failure to follow this caution may result in equipment damage or improper operation.

Do not bury more than 36 in. (914 mm) of refrigerant pipe in the ground. If any section of pipe is buried, there must be a 6 in. (152 mm) vertical rise to the valve connections on the outdoor units. If more than the recommended length is buried, refrigerant may migrate to the cooler buried section during extended periods of system shutdown. This causes refrigerant slugging and could possibly damage the compressor at start-up.



## WARNING

This appliance is not intended for use by persons (including children) with reduced physical, sensory or mental capabilities, or lack of experience and knowledge, unless they have been given supervision or instruction concerning use of the appliance by a person responsible for their safety. Children should be supervised to ensure that they do not play with the appliance.



## WARNING

Turn off the air conditioner and disconnect the power before performing any installation or repairing. Failure to do so can cause electric shock.

Installation must be performed by an authorized dealer or specialist. Defective installation can cause water leakage, electrical shock, or fire. Installation must be performed according to the installation instructions.

Improper installation can cause water leakage, electrical shock, or fire. Contact an authorized service technician for repair or maintenance of this unit. This appliance shall be installed in accordance with national wiring regulations.

Only use the included accessories, parts, and specified parts for installation. Using non-standard parts can cause water leakage, electrical shock, fire, and can cause the unit to fail.

Install the unit in a firm location that can support the unit's weight. If the chosen location cannot support the unit's weight, or the installation is not done properly, the unit may drop and cause serious injury and damage. Install drainage piping according to the instructions in this manual. Improper drainage may cause water damage to your home and property. For units that have an auxiliary electric heater, do not install the unit within 3 feet (1 meter) of any combustible materials.

If combustible gas accumulates around the unit, it may cause fire.

Do not turn on the power until all work has been completed.

When moving or relocating the air conditioner, consult experienced service technicians for disconnection and re-installation of the unit.

How to install the appliance to its support, please read the information for details in "indoor unit installation" and "outdoor unit installation" sections.

**NOTE: The air conditioner’s circuit board (PCB) is designed with a fuse to provide overcurrent protection. The specifications of the fuse are printed on the circuit board, for example: T3.15AL/250VAC, T5AL/250VAC, T3.15A/250VAC, T5A/250VAC, T20A/250VAC, T30A/250VAC,etc.**

**NOTE: Only a blast-proof ceramic fuse can be used.**

WARNING

**FOR FLAMMABLE REFRIGERANTS**

Do not use means to accelerate the defrosting process or to clean, other than those recommended by the manufacturer.

The appliance shall be stored in a room without continuously operating ignition sources (for example: open flames, an operating gas appliance or an operating electric heater).

Do not pierce or burn. Be aware that refrigerants may not contain an odor.

WARNING

**PERSONAL INJURY AND PROPERTY DAMAGE HAZARD**

For continued performance, reliability, and safety, the only approved accessories and replacement parts are those specified by the equipment manufacturer. The use of non-manufacturer approved parts and accessories could invalidate the equipment limited warranty and result in a fire risk, equipment malfunction, and failure.

Please review the manufacturer’s instructions and replacement parts catalogs available from your equipment supplier.

**R-454B**

Refrigerant  
Safety Group  
**A2L**

**R-454B**

WARNING - Risk of Fire due to Flammable Refrigerant Used. Follow Handling Instructions Carefully in Compliance with National Regulations

**NOTE: Risk of Fire. Flammable refrigerant used. To be repaired only by trained service personnel. Do not puncture refrigerant tubing.**

**1. Installation (where refrigerant pipes are allowed)**

- Any person who is involved with working on or breaking into a refrigerant circuit should hold a current valid certificate from an industry-accredited assessment authority, which authorizes their competence to handle refrigerants safely in accordance with an industry recognized assessment specification.
- Maintenance and repair requiring the assistance of other skilled personnel shall be carried out under the supervision of the person competent in the use of flammable refrigerants.
- That the installation of pipe-work shall be kept to a minimum.
- That pipe-work shall be protected from physical damage.

- Where refrigerant pipes shall be compliance with national gas regulations.
- That mechanical connections shall be accessible for maintenance purposes.
- Be more careful that foreign matter (oil, water, etc) does not enter the piping. Also, when storing the piping, securely seal the opening by pinching, taping, etc.
- Appliance shall be stored in a well ventilated area where the room size corresponds to the room area as specific for operation.
- Joints shall be tested with detection equipment with a capability of 1/8 oz (5g)/year of refrigerant or better, with the equipment in standstill and under operation or under a pressure of at least these standstill or operation conditions after installation.
- In cases that require mechanical ventilation, ventilation openings shall be kept clear of obstruction.

**LEAK DETECTION SYSTEM** installed. Unit must be powered except for service. For the unit with refrigerant sensor, when the refrigerant sensor detects refrigerant leakage, the indoor unit will display a error code and emit a buzzing sound, the compressor of outdoor unit will immediately stop, and the indoor fan will start running. The service life of the refrigerant sensor is 15 years. When the refrigerant sensor malfunctions, the indoor unit will display the error code FHCC. The refrigerant sensor can not be repaired and can only be replaced by the manufacture. It shall only be replaced with the sensor specified by the manufacture.

**2. Because a FLAMMABLE REFRIGERANT is used**

The requirements for installation space of appliance and/or ventilation requirements are determined according to:

- the mass charge amount (M) used in the appliance,
  - the installation location,
  - the type of ventilation of the location or of the appliance.
  - piping material, pipe routing, and installation shall include protection from physical damage in operation and service, and be in compliance with national and local codes and standards, such as ASHRAE 15, IAPMO Uniform Mechanical Code, ICC International Mechanical Code, or CSA B52. All field joints shall be accessible for inspection prior to being covered or enclosed.
  - that protection devices, piping, and fittings shall be protected as far as possible against adverse environmental effects, for example, the danger of water collecting and freezing in relief pipes or the accumulation of dirt and debris;
  - that piping in refrigeration systems shall be so designed and installed to minimize the likelihood of hydraulic shock damaging the system;
  - that steel pipes and components shall be protected against corrosion with a rustproof coating before applying any insulation;
  - that precautions shall be taken to avoid excessive vibration or pulsation;
  - the minimum floor area of the room shall be mentioned in the form of a table or a single figure without reference to a formula;
  - after completion of field piping for split systems, the field pipework shall be pressure tested with an inert gas and then vacuum tested prior to refrigerant charging, according to the following requirements:
- a. The minimum test pressure for the low side of the system shall be the low side design pressure and the minimum test pressure for the high side of the system shall be the high side design pressure, unless the high side of the system cannot be isolated from the low side of the system in which case the entire system shall be pressure tested to the low side design pressure.
  - b. The test pressure after removal of pressure source shall be maintained for at least 1 hour with no decrease of pressure indicated by the test gauge, with test gauge resolution not exceeding 5% of the test pressure.

- c. During the evacuation test, after achieving a vacuum level specified in the manual or less, the refrigeration system shall be isolated from the vacuum pump and the pressure shall not rise above 1500 microns within 10 minutes. The vacuum pressure level shall be specified in the manual, and shall be the lessor of 500 microns or the value required for compliance with national and local codes and standards, which may vary between residential, commercial, and industrial buildings.
- field-made refrigerant joints indoors shall be tightness tested according to the following requirements: The test method shall have a sensitivity of 1/8 oz (5g)/year of refrigerant or better under a pressure of at least 125% of the maximum allowable pressure. No leak shall be detected.

### 3. Qualification of workers

Any maintenance, service and repair operations must be required qualification of the working personnel. Every working procedure that effects safety means shall only be carried out by competent persons that joined the training and achieved competence should be documented by a certificate. The training of these procedures is carried out by national training organizations or manufacturers that are accredited to teach the relevant national competency standards that may be set in legislation. Examples for such working procedures are:

- breaking into the refrigerating circuit;
- opening of sealed components;
- opening of ventilated enclosures.

## Information Servicing

1. Checks to the area
 

Prior to beginning work on systems containing flammable refrigerants, safety checks are necessary to ensure that the risk of ignition is minimized. For repair to the refrigerating system, the following precautions shall be complied with prior to conducting work on the system.
2. Work procedure
 

Works shall be undertaken under a controlled procedure so as to minimize the risk of a flammable gas or vapor being present while the work is being performed.
3. General work area
 

All maintenance staff and others working in the local area shall be instructed on the nature of work being carried out. work in confined spaces shall be avoided.
4. Checking for presence of refrigerant
 

The area shall be checked with an appropriate refrigerant detector prior to and during work to ensure the technician is aware of potentially flammable atmospheres. Ensure that the leak detection equipment is suitable for use with flammable refrigerants (no sparking, adequately sealed, or intrinsically safe).
5. Presence of fire extinguisher
 

If any hot work is to be conducted on the refrigeration equipment or any associated parts, appropriate fire extinguishing equipment shall be available to hand. Have a dry power or CO2 fire extinguisher adjacent to the charging area.
6. No ignition sources
 

No person carrying out work in relation to a REFRIGERATING SYSTEM which involves exposing any pipe work shall use any sources of ignition in such a manner that it may lead to the risk of fire or explosion. All possible ignition sources, including cigarette smoking, should be kept sufficiently far away from the site of installation, repairing, removing and disposal, during which refrigerant can possibly be released to the surrounding space. Prior to work taking place, the area around the equipment is to be surveyed to make sure that there are no flammable hazards or ignition risks. “No Smoking” signs shall be displayed.
7. Ventilated area
 

Ensure that the area is in the open or that it adequately ventilated before breaking into the system or conducting any hot work. A degree of ventilation shall continue during the period that the work is carried out. The ventilation should safely disperse any released refrigerant and preferably expel it externally into the atmosphere.
8. Checks to the refrigeration equipment
 

Where electrical components are being changed, they shall be fit for the purpose and to the correct specification. At all times the manufacturer’s maintenance and service guidelines shall be followed. If in doubt consult the manufacturer’s technical department for assistance. The following checks shall be applied to installations using FLAMMABLE REFRIGERANTS:

  - The actual refrigerant charge is in accordance with the room size within which the refrigerant containing parts are installed;
  - The ventilation machinery and outlets are operating adequately and are not obstructed;
  - If an indirect refrigerating circuit is being used, the secondary circuits shall be checked for the presence of refrigerant;
  - Marking to the equipment continues to be visible and legible, marking and signs that are illegible shall be corrected;
  - Refrigeration pipe or components are installed in a position where they are unlikely to be exposed to any substance which may corrode refrigerant containing components, unless the components are constructed of materials which are inherently resistant to being corroded or are suitably protected against being so corroded.
9. Checks to electrical devices
 

Repair and maintenance to electrical components shall include initial safety checks and component inspection procedures. If a fault exists that could compromise safety, then no electrical supply shall be connected to the circuit until it is satisfactorily dealt with. If the fault cannot be corrected immediately but it is necessary to continue operation, and adequate temporary solution shall be used. This shall be reported to the owner of the equipment so all parties are advised. Initial safety checks shall include:

  - That capacitors are discharged: this shall be done in a safe manner to avoid possibility of sparking
  - That there no live electrical components and wiring are exposed while charging, recovering or purging the system
  - That there is continuity of earth bonding
10. Sealed electrical components shall be replaced.
11. Intrinsically safe components must be replaced.
12. Cabling
 

Check that cabling is not subjected to wear, corrosion, excessive pressure, vibration, sharp edges or any other adverse environmental effects. The check shall also take into account the effects of aging or continual vibration from sources such as compressors or fans.
13. Detection of flammable refrigerants
 

Under no circumstances shall potential sources of ignition be used in the searching for or detection of refrigerant leaks. A halide torch (or any other detector using a naked flame) shall not be used.

The following leak detection methods are deemed acceptable for refrigerant systems. Electronic leak detectors that have a sensitivity of 1/8 oz (5g) may be used to detect refrigerant leaks but, in the case of FLAMMABLE REFRIGERANTS, the sensitivity may not be adequate, or may need re-calibration. (Detection equipment shall be calibrated in a refrigerant-free area.) Ensure that the detector is not a potential source of ignition and is suitable for the refrigerant used. Leak detection equipment shall be set at a percentage of the LFL of

the refrigerant and shall be calibrated to the refrigerant employed, and the appropriate percentage of gas (25% maximum) is confirmed. Leak detection fluids are also suitable for use in external leak detection.

**NOTE: Examples of leak detection fluids are as follows:**

- **Bubble method**
- **Fluorescent method agents**

If a leak is suspected, all naked flames shall be removed/extinguished.

If a leakage of refrigerant is found which requires brazing, all of the refrigerant shall be recovered from the system, or isolated (by means of shut off valves) in a part of the system remote from the leak. See the following instructions of removal of refrigerant.

**14. Removal and evacuation**

When breaking into the refrigerant circuit to make repairs - or for any other purpose conventional procedures shall be used. However, for flammable refrigerants it is important that best practice be followed, since flammability is a consideration.

The following procedure shall be adhered to:

- a. safely remove refrigerant following local and national regulations;
- b. evacuate;
- c. purge the circuit with nitrogen;
- d. evacuate;
- e. continuously flush or purge with nitrogen when using flame to open circuit; and open the circuit.

The refrigerant charge shall be recovered into the correct recovery cylinders. Charging must be performed by liquid charging method. For appliances containing flammable refrigerants, the system shall be purged with oxygen-free nitrogen to render the appliance safe for flammable refrigerants. This process might need to be repeated several times. Compressed air or oxygen shall not be used for purging refrigerant systems.

For appliances containing flammable refrigerants, refrigerants purging shall be achieved by breaking the vacuum in the system with oxygen-free nitrogen and continuing to fill until the working pressure is achieved, then venting to atmosphere, and finally pulling down to a vacuum (optional for A2L). This process shall be repeated until no refrigerant is within the system (optional for A2L). When the final oxygen-free nitrogen charge is used, the system shall be vented down to atmospheric pressure to enable work to take place.

The outlet for the vacuum pump shall not be close to any potential ignition sources, and ventilation shall be available.

**15. Charging procedures**

In addition to conventional charging procedures, the following requirements shall be followed:

- Works shall be undertaken with appropriate tools only. If uncertain, consult the manufacturer of the tools for use with flammable refrigerants.
- Ensure that contamination of different refrigerants does not occur when using charging equipment. Hoses or lines shall be as short as possible to minimize the amount of refrigerant contained in them.
- Cylinders shall be kept upright.
- Charging must be performed by liquid charging method.
- Ensure that the refrigeration system is grounded prior to charging the system with refrigerant.
- Label the system when charging is complete.
- Extreme care shall be taken to avoid overfilling the refrigeration system.
- Prior to recharging the system, it shall be pressure tested with oxygen free nitrogen (OFN). The system shall be leak tested on completion of charging but before commissioning. A follow up leak test shall be carried out prior to leaving the site.

**16. Decommissioning**

Before carrying out this procedure, it is essential that the technician is completely familiar with the equipment and all its detail. It is recommended good practice that all refrigerants are recovered safely. Prior to the task being carried out, an oil and refrigerant sample shall be taken in case analysis is required prior to re-use of recovered refrigerant. It is essential that electrical power is available before the task is commenced.

- a. Become familiar with the equipment and its operation
- b. Isolate system electrically
- c. Before attempting the procedure, ensure the following:
  - Mechanical handling equipment is available, if required, for handling refrigerant cylinders
  - All personal protective equipment is available and being used correctly
  - The recovery process is supervised at all times by a competent person
  - Recovery equipment and cylinders conform to the appropriate standards
- d. Pump down refrigerant system, if possible.
- e. If a vacuum is not possible, make a manifold so that refrigerant can be removed from various parts of the system.
- f. Make sure that cylinder is situated on the scales before recovery takes place.
- g. Start the recovery machine and operate in accordance with instructions.
- h. Do not overfill cylinders (no more than 80% volume liquid charge).
- i. Never exceed the maximum working pressure of the cylinder.
- j. When the cylinders have been filled correctly and the process complete, make sure that the cylinders and the equipment are removed from site promptly and all isolation valves on the equipment are closed off.
- k. Recovered refrigerant shall not be charged into another refrigeration system unless it has been cleaned and checked.

**17. Labeling**

Equipment shall be labeled stating that it has been decommissioned and emptied of refrigerant. The label shall be dated and signed. For appliances containing FLAMMABLE REFRIGERANTS, ensure that there are labels on the equipment stating the equipment contains FLAMMABLE REFRIGERANT.

**18. Recovery**

When removing refrigerant from a system, either for servicing or decommissioning, it is recommended good practice that all refrigerants are removed safely.

When transferring refrigerant into cylinders, ensure that only appropriate refrigerant recovery cylinders are employed. Ensure that the correct number of cylinders for holding the total system charge is available. All cylinders to be used are designated for the recovered refrigerant and labeled for that refrigerant (i. e. special cylinders for the recovery of refrigerant). Cylinders shall be complete with pressure-relief valve and associated shut-off valves in good working order. Empty recovery cylinders are evacuated and, if possible, cooled before recovery occurs.

The recovery equipment shall be in good working order with a set of instructions concerning the equipment that is at hand and shall be suitable for the recovery of the flammable refrigerant. If in doubt, the manufacturer should be consulted. In addition, a set of calibrated weighing scales shall be available and in good working order. Hoses shall be complete with leak-free disconnect couplings and in good condition.

The recovered refrigerant shall be processed according to local legislation in the correct recovery cylinder, and the relevant waste transfer note arranged. Do not mix refrigerants in recovery units and especially not in cylinders.

If compressors or compressor oils are to be removed, ensure that they have been evacuated to an acceptable level to make certain that flammable refrigerant does not remain within the lubricant. The compressor body shall not be heated by an open flame or other ignition sources to accelerate this process. When oil is drained from a system, it shall be carried out safely.

19. Transportation, marking, and storage for units
  - a. Transport of equipment containing flammable refrigerants.
    - Compliance with the transport regulations.
  - b. Marking of equipment using signs.
    - Compliance with local regulations.
  - c. Disposal of equipment using flammable refrigerants.
    - Compliance with national regulations.
  - d. Storage of equipment/appliances
    - The storage of equipment should be in accordance with the manufacturer’s instructions.
  - e. Storage of packed (unsold) equipment
    - Storage package protection should be constructed such that mechanical damage to the equipment inside the package will not cause a leak of the refrigerant charge. The maximum number of pieces of equipment permitted to be stored together will be determined by local regulations.

**DEHUMIDIFICATION (DRY)**





In DEHUMIDIFICATION mode, the system dries, filters and slightly cools the room air temperature. This mode prioritizes air dehumidification but it does not take the place of a dehumidifier.

For indoor and outdoor unit compatibility, see Table 1, Table 6 on page 8, and Table 7 on page 8.

**Table 1 — Indoor / Outdoor Unit Matching**

INDOOR UNIT	OUTDOOR UNIT
Single Zone Compatible	D5CSHAH
	D5CSRAH
Multi Zone Compatible	D5CMHAH
	D5CMRAH

**Table 2 — Symbols displayed on the indoor unit or outdoor unit**

	<b>WARNING</b>	This symbol shows that this appliance used a flammable refrigerant. If the refrigerant is leaked and exposed to an external ignition source, there is a risk of fire.
	<b>CAUTION</b>	This symbol shows that the operation manual should be read carefully.
	<b>CAUTION</b>	This symbol shows that a service personnel should be handling this equipment with reference to the installation manual.
	<b>CAUTION</b>	
	<b>CAUTION</b>	This symbol shows that information is available such as the operating manual or installation manual.



60K	D5FCFAH58XAK
-----	--------------

## ELECTRICAL DATA

**Table 5 — Electrical Data**

INDOOR UNIT		18K	24K	36K	48K	60K
V-Ph-Hz		(208/230V)	(208/230V)	(208/230V)	(208/230V)	(208/230V)
Minimum Circuit Ampacity (MCA)	A	1.9	2.5	3	3	3
Maximum Overcurrent Protection (MOP)	A	15	15	15	15	15
Voltage-Phase-Frequency		208/230-1-60				
Max – Min Voltage Range		253-187				
<b>COOLING*</b>						
Power Consumption	(W)	1350	1833	3033	5106	6000
Running Current	(A)	8.7	8.2	13.3	22.5	26.2
<b>HEATING*</b>						
Power Consumption	(W)	1814	2194	3385	5330	5823
Running Current	(A)	11	10.1	15.1	24.2	26.1

### LEGEND

**FLA** - Full Load Amps

**MCA** - Minimum Circuit Amps

**MOP** - Maximum Overcurrent Protection

**NOTE:** Cooling and heating electrical specifications in Table 5 is with D5CSHA.

## COMPATIBILITY

**Table 6 — Compatibility**

INDOOR UNIT		MULTIZONE HEAT PUMP OUTDOOR UNIT					
		D5CMRAH18CAK	D5CMHAH24DAK	D5CMHAH30EAK	D5CMHAH36EAK	D5CMHAH48FAK	D5CMHAH55FAK
		D5CMHAH18CAK	D5CMRAH24DAK	D5CMRAH30EAK	D5CMRAH36EAK	D5CMRAH48FAK	D5CMRAH55FAK
Under ceiling Console	D5FCFAH18XAK	•	•	•	•	•	•
	D5FCFAH24XAK		•	•	•	•	•

**Table 7 — Compatibility**

INDOOR UNIT		SINGLE ZONE HEAT PUMP OUTDOOR UNIT				
		D5CSHAH18AAK	D5CSHAH24AAK	D5CLHAH36AAK	D5CLHAH48AAK	D5CLHAH58AAK
		D5CSRAH18AAK	D5CRAH24AAK	D5CLRAH36AAK	D5CLRAH48AAK	D5CLRAH58AAK
Under ceiling Console	D5FCFAH18XAK	•				
	D5FCFAH24XAK		•			
	D5FCFAH36XAK			•		
	D5FCFAH48XAK				•	
	D5FCFAH58XAK					•

# PRODUCT OVERVIEW

NOTE: Illustrations in this manual are for explanatory purposes. The actual shape of your indoor unit may vary.

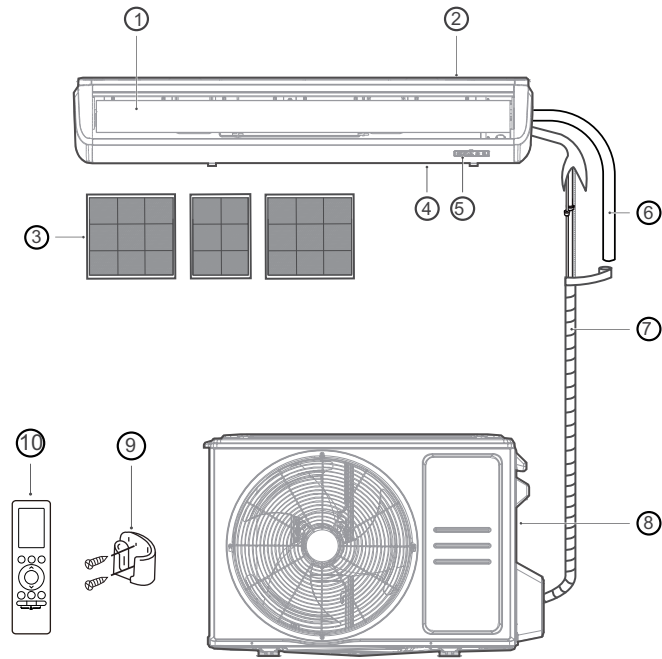

- ① Air flow louver (air outlet)
- ② Installation part
- ③ Air filter
- ④ Air inlet (with air filter in it)
- ⑤ Display panel
- ⑥ Drain pipe
- ⑦ Refrigerant piping (purchase separately)
- ⑧ Outdoor unit
- ⑨ Remote controller holder (purchase separately)
- ⑩ Remote controller

**Fig. 2 — Product Overview**

## Indoor Units

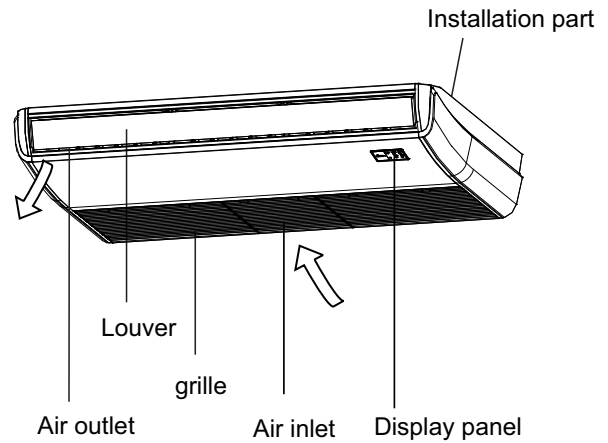

**Fig. 3 — Ceiling and Floor (Floor Installation)**



**Fig. 4 — Ceiling and Floor (Ceiling Installation)**

## PART NAMES





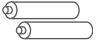





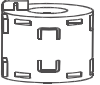

**Fig. 5 —Part Names**

## PRODUCT INSTALLATION

### ACCESSORIES

The air conditioning system comes with the following accessories. Use all of the installation parts and accessories to install the air conditioner. Improper installation may result in water leakage, electrical shock and fire, or cause the equipment to fail. The items are not included with the air conditioner must be purchased separately.

**Table 8 — Accessories**

NAME	QUANTITY	SHAPE	NAME	QUANTITY	SHAPE
Manual	2		Remote controller	1	
Outlet pipe sheath	1		Batteries	2	
Outlet pipe clasp	2		Remote controller holder	1	
Conduit installation plate	1		Screw for remote controller holder	2	
Copper nut	2		Magnetic ring	1	
Rubber Ring	3				

### Optional Accessories

There are two types of wired controls. Select a controller based on customer preferences and requirements and install in an appropriate place. Refer to catalogs and technical literature for guidance on selecting a suitable controller.

**Table 9 — Optional Accessories**

MODEL NO.	DESCRIPTION	FOR MODELS
KSACN1201AAA	Wired Non-Programmable Controller	All Sizes
KSACN1401AAA	Wired Programmable Controller with Built In WiFi	All Sizes

**NOTE: WIFI dongle is not compatible with this indoor unit.**

### Pipe Specifications

**Table 10 — Pipe Specifications**

NAME	MODEL	PIPE SPECIFICATIONS		REMARK
		LIQUID SIDE	GAS SIDE	
CONNECTING PIPE ASSEMBLY	18K	Ø1/4in(Ø6.35mm)	Ø1/2in(Ø12.7mm)	Pipes are not included in the accessories and you need to purchase it separately from the local dealer.
	24K	Ø3/8in(Ø9.52mm)	Ø5/8in(Ø16mm)	
	36K	Ø3/8in(Ø9.52mm)	Ø3/4in(Ø19mm)	
	48K	Ø3/8in(Ø9.52mm)	Ø3/4in(Ø19mm)	
	60K	Ø3/8in(Ø9.52mm)	Ø3/4in(Ø19mm)	

# WIRING DIAGRAMS

**NOTE:** Review the diagram label on your unit.

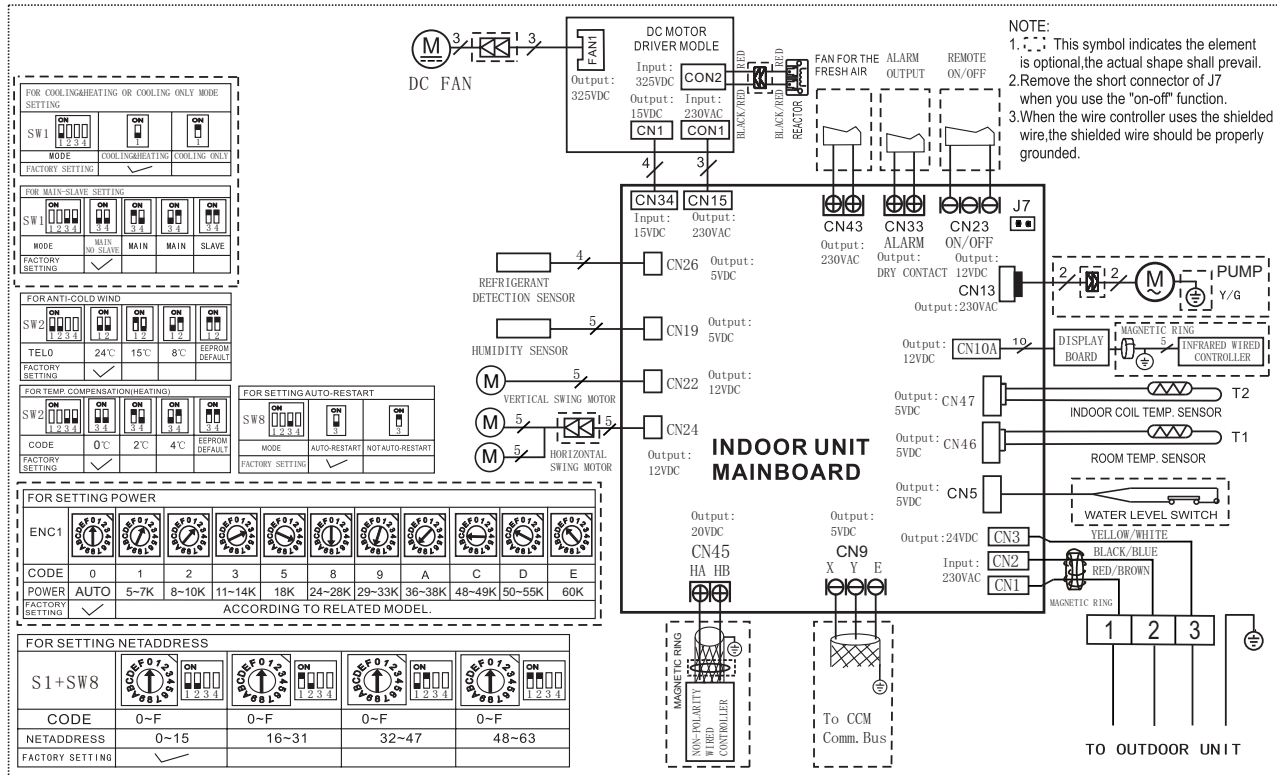

**Fig. 6 — Sizes 18K - 24K**

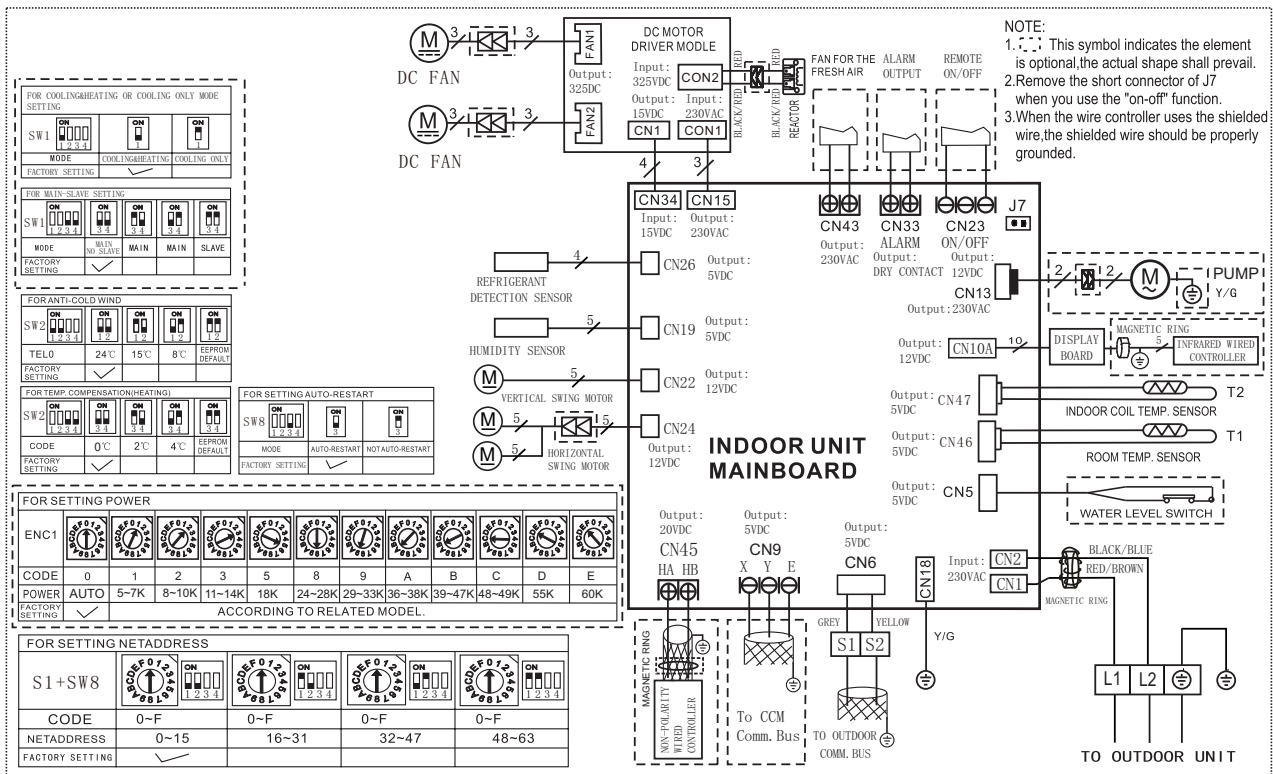
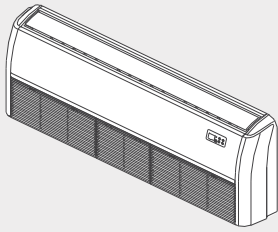

**Fig. 7 — Sizes 36K - 60K**

**NOTE:** Refer to the diagram label on the unit.

# INSTALLATION SUMMARY

A



Install the indoor unit

B

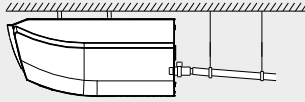

Install the drainpipe

C

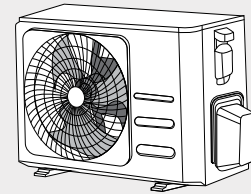

Install the outdoor unit

D

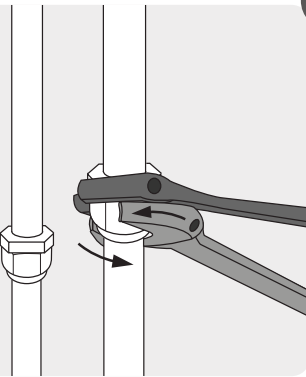

Connect the refrigerant pipes

E

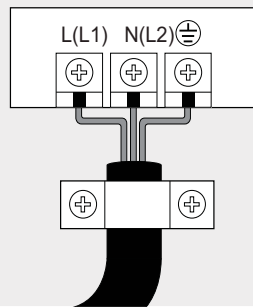

Connect the wires

F

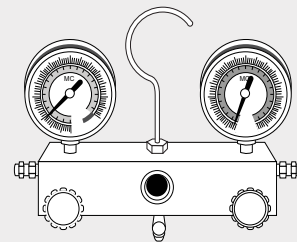

Evacuate the refrigeration system

G

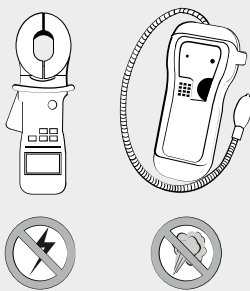

Perform a test run

**NOTE:** Refer to the **Outdoor Installation manual** for steps pertaining to the outdoor unit and the system checks.

## A. INSTALL INDOOR UNIT

### Step 1 - Select the Installation Location

**NOTE:** Before installing the indoor unit, refer to the label on the product box to ensure that the model number of the indoor unit matches the model number of the outdoor unit. Panel installation should be performed after piping and wiring have been completed.

Proper installation locations meet the following standards:



Enough room exists for installation and maintenance.

Enough room exists for the connecting the pipe and drainpipe.



There is no direct radiation from heaters.

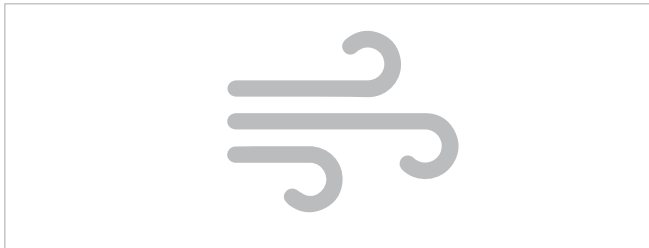

The air inlet and outlet are not blocked.

The airflow can fill the entire room.

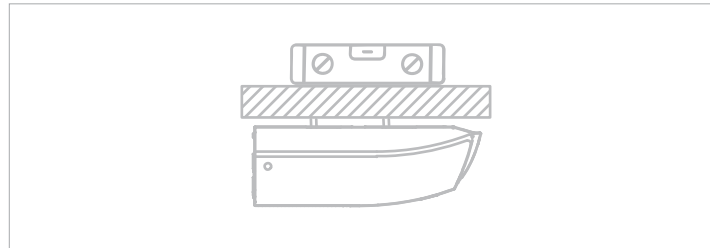

The ceiling is horizontal and its structure can sustain the weight of the indoor unit.

**DO NOT** install unit in the following locations:

- ⊘ Areas with oil drilling or fracking
- ⊘ Coastal areas with high salt content in the air
- ⊘ Areas with caustic gases in the air, such as hot springs
- ⊘ Areas that experience power fluctuations, such as factories
- ⊘ Enclosed spaces, such as cabinets
- ⊘ Kitchens that use natural gas
- ⊘ Areas with strong electromagnetic waves
- ⊘ Areas that store flammable materials or gas
- ⊘ Rooms with high humidity, such as bathrooms or laundry rooms

## Step 2 - Confirm the Various Sizes (Unit Dimensions)

### Recommended distances between the indoor unit

The distance between the mounted indoor unit should meet the specifications shown in Fig. 8.

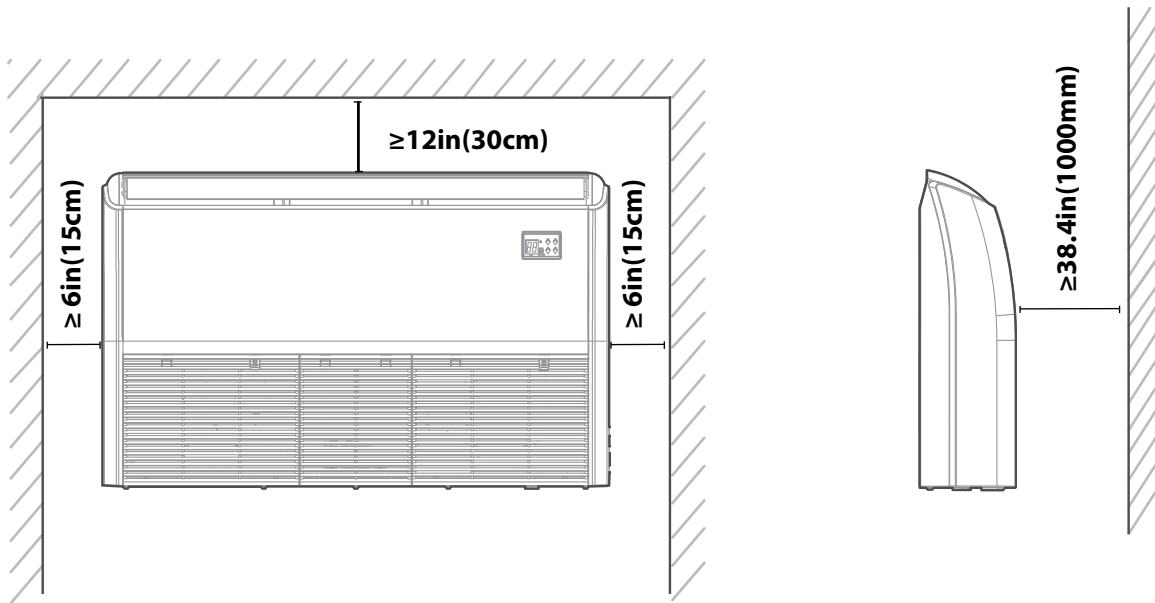

### Indoor parts installation size

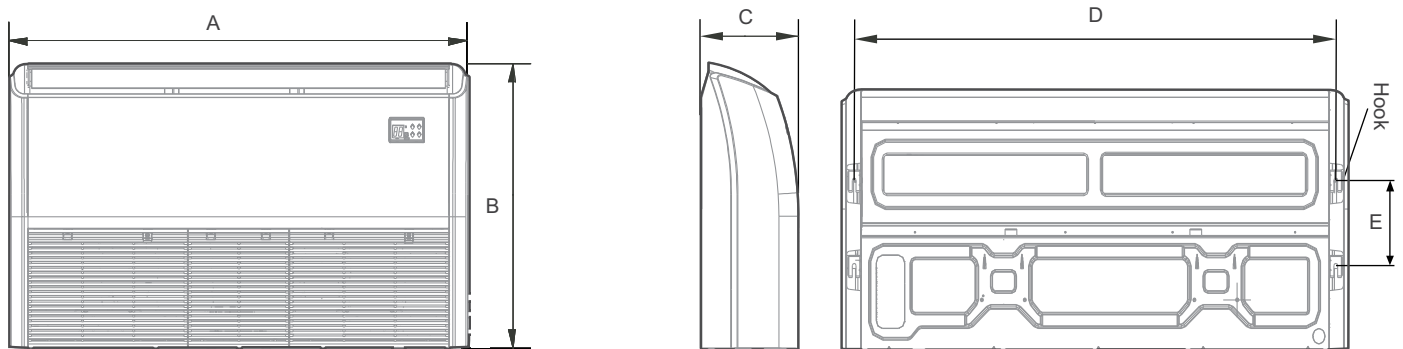

**Fig. 8 — Dimensions**

**Table 11 — Dimensions**

MODEL (BTU/H)	LENGTH OF A (INCH/MM)	LENGTH OF B (INCH/MM)	LENGTH OF C (INCH/MM)	LENGTH OF D (INCH/MM)	LENGTH OF E (INCH/MM)
18K~24K	42/1068	26.6/675	9.3/235	38.7/983	8.7/220
36K~60K	65/1650	26.6/675	9.3/235	61.6/1565	8.7/220

### Step 3 - Hang the Indoor Unit

1. Install the four suspension bolts.
2. Mount the indoor unit. You will need two people to lift and secure it. Insert suspension bolts into the unit's hanging holes. Fasten them using the included washers and nuts.

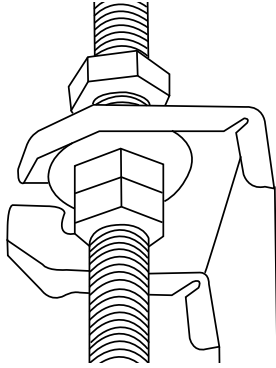

**Fig. 9 — Suspension Bolt**

3. Remove the side board and the grille (see Table 11 on page 14).

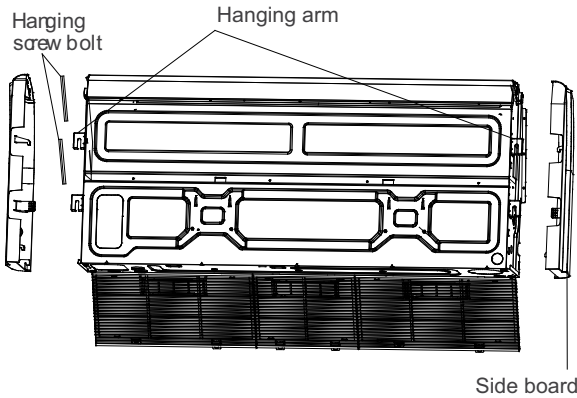

**Fig. 10 — Remove the side board and grill**

4. Mount the indoor unit onto the hanging screw bolts with a block. Position the indoor unit on a flat level by using a level to prevent leaks.

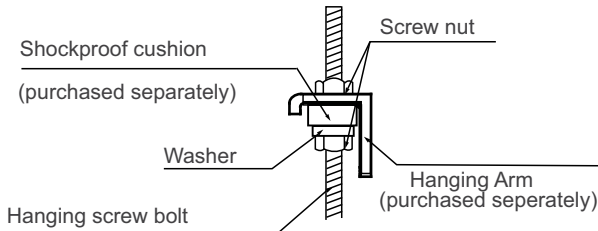

**Fig. 11 — Mount the indoor unit**

**NOTE:** Confirm the minimum drain tilt is 1/8" per foot or more.  
**NOTE:** Follow the local codes regarding vibration installation device.

### Ceiling Installation

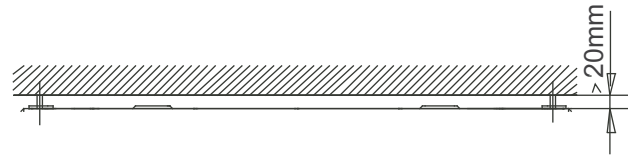

D. Refrigerant pipe connection

(D. gas side)

E. Refrigerant pipe connection

(E. Liquid side)

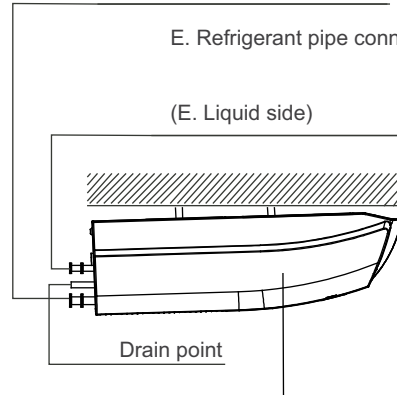

Drain point

Downward slope between 1/8" per foot (2.5cm per 30cm)

**Fig. 12 — Ceiling Installation**

### Install the conduit installation plate (if supplied)

1. Secure the sheath connector (field supplied) on the wire hole of the conduit installation plate.
2. Secure the conduit installation plate on the chassis of the unit.

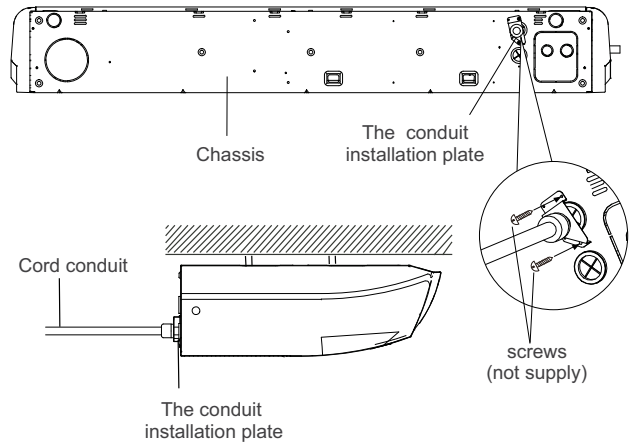

**Fig. 13 — Secure the conduit installation plate**

## Wall-Mounted Installation

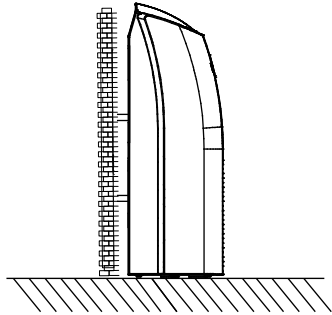

**Fig. 14 — Wall-Mounted Installation**

### Install the conduit installation plate (if supplied)

1. Secure the sheath connector (field supplied) on the wire hole of the conduit installation plate.
2. Fix the conduit installation plate on the electric control box.

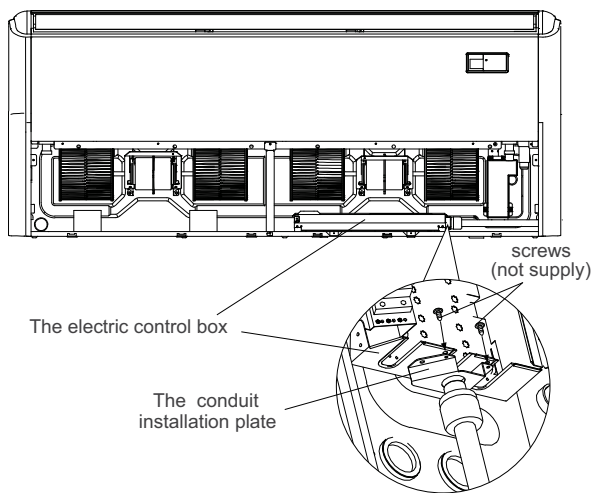
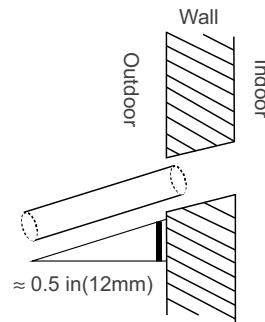
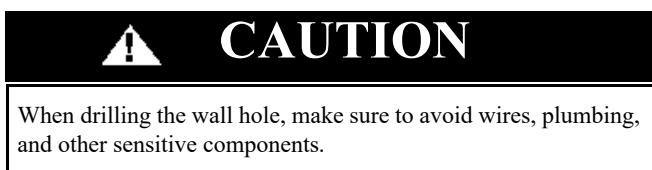

**Fig. 15 — Secure the conduit installation plate**

## B. INSTALL DRAIN PIPE

### Step 1 - Drill Wall Hole and Connect Drain Piping

1. Determine the location of the wall hole based on the location of the outdoor unit.
2. Using a 2.5in(65mm) or 3.54in(90mm) core drill, drill a hole in the wall. Ensure that the hole is drilled at a slight downward angle, so that the outdoor end of the hole is lower than the indoor end by about 0.5in(12mm). This will ensure proper water drainage.
3. Place the protective wall cuff in the hole. This protects the edges of the hole and will help seal it when you finish the installation process.



**Fig. 16 — Wall hole**

4. **Connect Drain Hose** - The drainpipe is used to drain water away from the unit. Improper installation may cause unit and property damage.

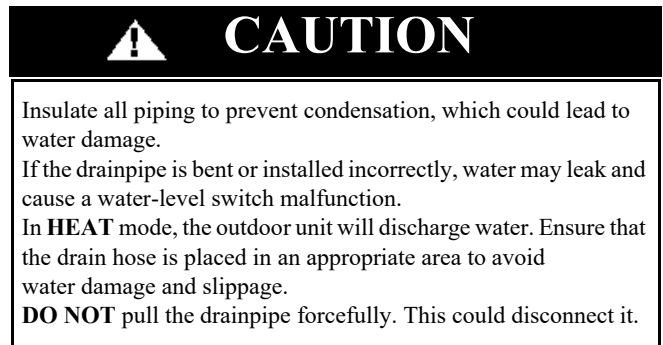

**NOTE ON PURCHASING PIPES:** Installation requires a polyethylene tube (exterior diameter = 1.46-1.54in/3.7-3.9cm, interior diameter = 1.26in/3.2cm), which can be obtained at your local hardware store or dealer.

### Step 2 - Indoor Drainpipe Installation

Install the drainpipe as illustrated in Fig.17.

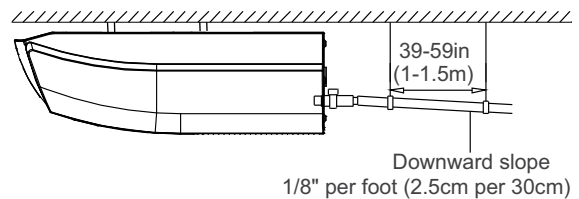

**Fig. 17 — Indoor Drainpipe installation**

1. Cover the drainpipe with heat insulation to prevent condensation and leakage.
2. Attach the mouth of the drain hose to the unit's outlet pipe. Sheath the mouth of the hose and clip it firmly with a pipe clasp.

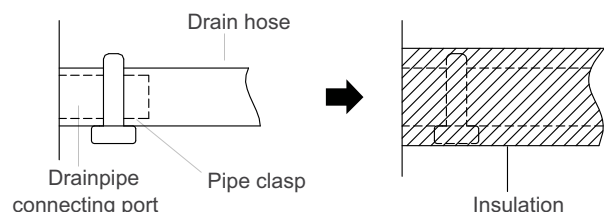

**Fig. 18 — Indoor Pipe Installation**

- When using an extended drainpipe, tighten the indoor connection with an additional protection tube to prevent it from pulling loose.
- The drainpipe should slope downward at a gradient of at least 1/8" per foot (2.5cm per 30cm) to prevent water from flowing back into the air conditioner.
- To prevent the pipe from sagging, space hanging wires every 39-59in (1-1.5m).
- Incorrect installation could cause water to flow back into the unit and flood.

**NOTE: When connecting multiple drainpipes, install the pipes as illustrated in Figure 19.**

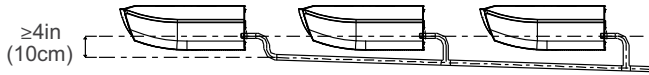

**Fig. 19 — Connecting Multiple Drainpipes**

3. Pass the drain hose through the wall hole. Ensure the water drains to a safe location where it will not cause water damage or a slipping hazard.

**NOTE: The drainpipe outlet should be at least 1.9in (50mm) above the ground. If it touches the ground, the unit may become blocked and malfunction. If you discharge the water directly into a sewer, make sure that the drain has a U or S pipe to catch odors that might otherwise come back into the house.**

## C. WIRING CONNECTION

### Wiring Precautions

All wiring must comply with local and national electrical codes, regulations and must be installed by a licensed electrician. All electrical connections must be made according to the Electrical Connection Diagram located on the panels of the indoor and outdoor units. If there is a serious safety issue with the power supply, stop work immediately. Explain your reasoning to the client, and refuse to install the unit until the safety issue is properly resolved.

Power voltage should be within 90-110% of rated voltage. Insufficient power supply can cause malfunction, electrical shock, or fire. Installation of an external surge suppressor at the outdoor disconnect is recommended.

If connecting power to fixed wiring, a switch or circuit breaker that disconnects all poles and has a contact separation of at least 1/8in (3mm) must be incorporated in the fixed wiring. The qualified technician must use an approved circuit breaker or switch.

Only connect the unit to an individual branch circuit. Do not connect another appliance to that outlet.

Make sure to properly ground the air conditioner. Every wire must be firmly connected. Loose wiring can cause the terminal to overheat, resulting in product malfunction and possible fire. Do not let wires touch or rest against refrigerant tubing, the compressor, or any moving parts within the unit.

If the unit has an auxiliary electric heater, it must be installed at least 40in (1 meter) away from any combustible materials.

To avoid getting an electric shock, never touch the electrical components soon after the power supply has been turned off. After turning on the power, always wait 10 minutes or more before you touch the electrical components.

Ensure that you do not cross your electrical wiring with your signal wiring. This may cause distortion, interference or possibly damage to circuit boards. No other equipment should be connected to the same power circuit. Connect the outdoor wires before connecting the indoor wires.

**WARNING**

Before performing any electrical work, read these warnings.

**WARNING**

Before performing any electrical work or working work, turn off the main power to the system.

## CONNECTION DIAGRAMS

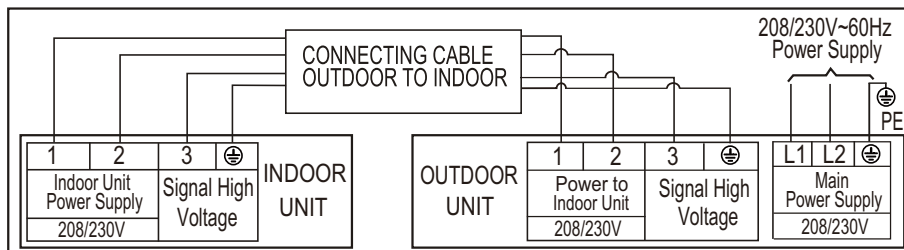

**Fig. 20 — Connection Diagram 18K and 24**

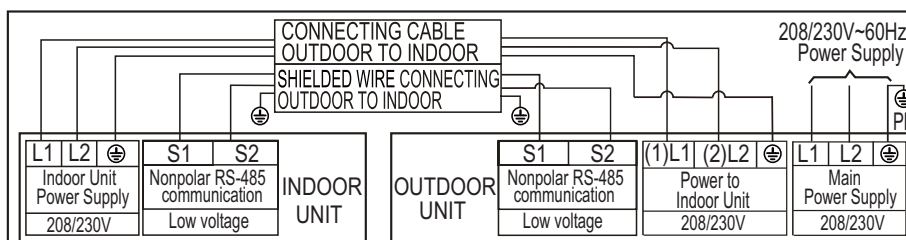

**Fig. 21 — Connection Diagram 36K/48K/60K**

## INDOOR UNIT WIRING

1. Prepare the cable for connection
  - a. Using wire strippers, strip the rubber jacket from both ends of the signal cable to reveal about 5.9in(150mm) of the wire.
  - b. Strip the insulation from the ends of the wires.
  - c. Using a wire crimper, crimp the u-lugs to the ends of the wires.
2. Open the front panel of the indoor unit. Using a screwdriver, remove the cover of the electric control box on your indoor unit.
3. Thread the power cable and the signal cable through the wire outlet.
4. Connect the u-lugs to the terminals. Match the wire colors/labels with the labels on the terminal block. Firmly screw the u-lug of each wire to its corresponding terminal. Refer to the Serial Number and Wiring Diagram located on the cover of the electric control box.

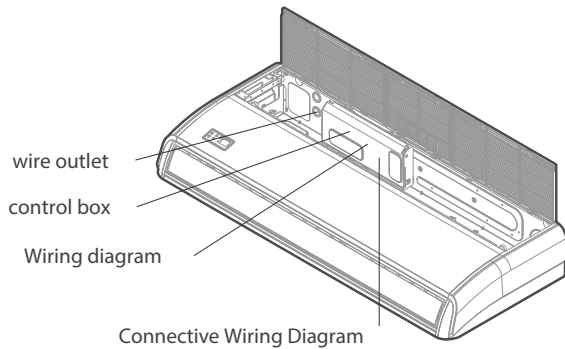

**Fig. 22 — Connective Wiring Diagram**  
Magnetic Ring (if supplied and packed with the accessories)

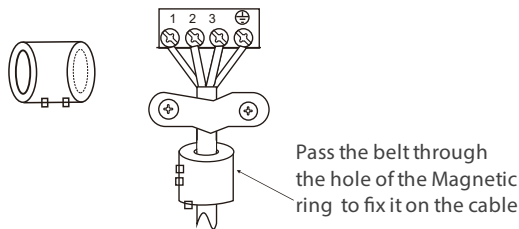

**Fig. 23 — Magnetic Ring**

**CAUTION**

While connecting the wires, strictly adhere to the wiring diagram. The refrigerant circuit can become very hot. Keep the interconnection cable away from the copper tube.

5. Clamp down the cable with the cable clamp. The cable must not be loose or pull on the u-lugs.
6. Reattach the electric box cover.

## D. CONNECT THE REFRIGERANT PIPES

**CAUTION**

The branching pipe must be installed horizontally. An angle of more than 10° may cause malfunction.  
**DO NOT** install the connecting pipe until both the indoor and outdoor units have been installed. Insulate both the gas and liquid piping to prevent condensation.

1. **Cut the Pipes:** When preparing refrigerant pipes, take extra care to cut and flare them properly. This ensures efficient operation and minimize the need for future maintenance.
  - a. Measure the distance between the indoor and outdoor units.
  - b. Using a pipe cutter, cut the pipe a little longer than the measured distance.
  - c. Ensure the pipe is cut at a perfect 90° angle.

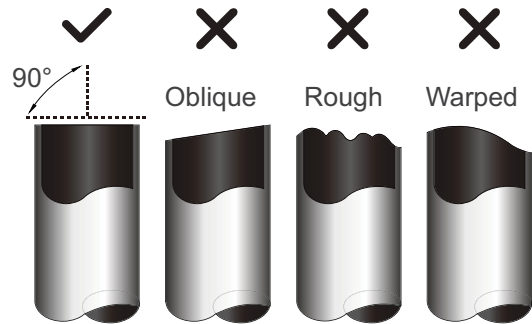

**Fig. 24 — Cut Pipe**

**NOTE: DO NOT DEFORM PIPE WHILE CUTTING.** Be sure not to damage, dent, or deform the pipe while cutting. This will drastically reduce the heating.

2. **Remove the Burrs:** Burrs can affect the air-tight seal of refrigerant piping connection. They must be completely removed.
  - a. Hold the pipe at a downward angle to prevent burrs from falling into the pipe.
  - b. Use a reamer or deburring tool, and remove all burrs from the cut section of the pipe.

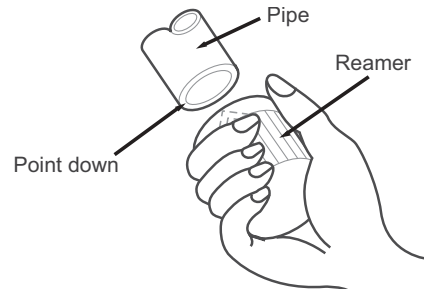

**Fig. 25 — Reamer**

3. **Flare Pipe Ends:** Proper flaring is essential to achieve an airtight seal.
  - a. After removing the burrs from the cut pipe, seal the ends with PVC tape to prevent foreign materials from entering the pipe.
  - b. Sheath the pipe with insulating material.
  - c. Place flare nuts on both ends of pipe. Ensure they are facing in the right direction, because you can not put them on or change their direction after flaring.

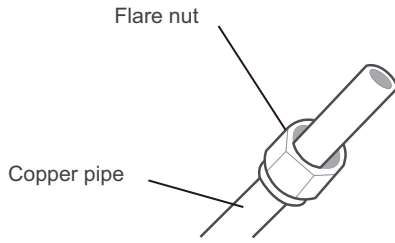

**Fig. 26 — Flare Nut**

- d. Remove PVC tape from ends of pipe when ready to perform flaring work.
- e. Clamp flare on the end of the pipe. The end of the pipe must extend beyond the flare form.

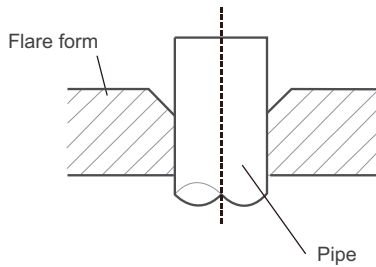

**Fig. 27 — Flare**

- f. Place flaring tool onto the form.
- g. Turn the handle of the flaring tool clockwise until the pipe is fully flared.

**Table 12 — Piping Extension Beyond Flare Form**

PIPE GAUGE	TIGHTENING TORQUE	FLARE DIMENSIONS (A)	FLARE SHAPE
Ø1/4in (Ø6.35mm)	13.27-14.75 lbf-ft 18-20 N.m	0.33~0.34in (8.4~8.7mm)	
Ø3/8in (Ø9.52mm)	23.6-28.76 lbf-ft 32-39 N.m	0.52~0.53in (13.2~13.5mm)	
Ø1/2in (Ø12.7mm)	36.14-43.51 lbf-ft 49-59 N.m	0.64~0.65in (16.2~16.5mm)	

- h. Remove the flaring tool and flare form, then inspect the end of the pipe for cracks and even flaring.
4. Connect Pipes: Connect the copper pipes to the indoor unit first, then connect it to the outdoor unit. You should first connect the low-pressure pipe, then the high pressure pipe.
- a. When connecting the flare nuts, apply a thin coat of refrigeration oil to the flared ends of the pipes.
  - b. Align the center of the two pipes that you will connect.

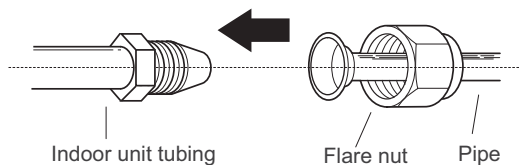

**Fig. 28 — Connect the Pipes**

- c. Tighten the flare nut snugly by hand.
- d. Using a wrench, grip the nut on the unit tubing.
- e. While firmly gripping the nut, use a torque wrench to tighten the flare nut according to the torque values in Table 12 on page 19.

**NOTE: Use both an adjustable wrench and a torque wrench when connecting or disconnecting pipes to/from the unit.**

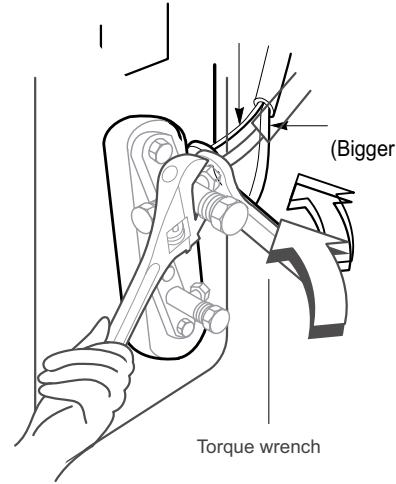

**Fig. 29 — Torque Wrench**

**⚠ CAUTION**

Ensure to wrap insulation around the piping.  
 Direct contact with the bare piping may result in burns or frostbite.  
 Ensure the pipe is properly connected.  
 Over tightening may damage the bell mouth and under tightening may lead to leakage.

**NOTE: Minimum Bend Radius: Carefully bend the tubing in the middle according to the diagram below. DO NOT bend the tubing more than 90° or more than 3 times.**

Use appropriate tool

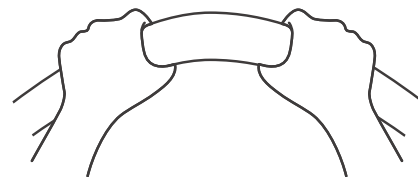

min-radius 3.9in (10mm)

**Fig. 30 — Bend Radius**

- f. After connecting the copper pipes to the indoor unit, wrap the power cable, signal cable and the piping together with binding tape.

**NOTE: DO NOT intertwine signal cable with other wires. While bundling these items together. DO NOT intertwine or cross the signal cable with any other wiring.**

## TROUBLESHOOTING

**Table 13 — Error Codes**

Display	Malfunction and Protection Indication
<b>EC07</b>	ODU Fan Speed Out of Control
<b>EC51</b>	ODU EEPROM Parameter Error
<b>EC52</b>	ODU Coil Temperature Sensor(T3) error
<b>EC53</b>	ODU Ambient Temperature Sensor (T4) Error
<b>EC54</b>	COMP. Discharge Temperature Sensor (TP) Error
<b>EC56</b>	IDU Coil Temperature Sensor (T2B) Error
<b>ECC1</b>	Other IDU Refrigerant Sensor Detects Leakage (Multi-zone)*
<b>EH00</b>	IDU EEPROM Malfunction
<b>EH03</b>	IDU Fan Speed Out of Control
<b>EH0A</b>	IDU EEPROM Parameter Error
<b>EH0E</b>	Water Level Alarm Malfunction
<b>EH12</b>	Main Unit or Secondary Units Malfunction
<b>EH3A</b>	External Fan DC bus voltage is too low protection
<b>EH3b</b>	External Fan DC bus voltage is too high fault
<b>EH60</b>	IDU Room Temperature (T1) Error
<b>EH61</b>	IDU Coil Temperature Sensor (T2) Error
<b>EH6a</b>	Communication Error between the indoor unit and the external fan module
<b>EHC1</b>	Refrigerant Sensor Detects Leakage
<b>EHC2</b>	Refrigerant Sensor is out of range and a leak is detected
<b>EHC3</b>	Refrigerant Sensor is out of range*
<b>EL01</b>	IDU and ODU Communication Error
<b>EL0C</b>	System lacks refrigerant
<b>EL11</b>	Communication Malfunction between the main and secondary units
<b>FH07</b>	IDU lift panel communication failure/IDU opening and closing failure
<b>FHCC</b>	Refrigerant Sensor Error*
<b>PC00</b>	ODU IPM Module Protection
<b>PC01</b>	ODU Voltage Protection
<b>PC02</b>	Compressor To (or IPM Module Protection
<b>PC03</b>	Pressure Protection (Low or High Pressure)
<b>PC04</b>	Inverter Compressor Drive Error
<b>PC0L</b>	Low Ambient Temperature Protection
<b>NOTE:</b> The digital tube will display <b>FC</b> in the <b>FORCED COOLING</b> mode. <b>FC</b> is <b>NOT</b> an error code. *Applicable to the units with refrigerant sensors only.	

**Table 14 — Refrigerant Leak Detection Errors**

<b>EHC1</b>	Refrigerant Sensor detects a leak
<b>EHC2</b>	Working condition of the refrigerant sensor is out of range and a leak is detected

If you receive one of the codes in Table 14, call a technician as soon as possible. No need to panic, the unit goes into TURBO mode until the error code is cleared. There is a “beep” noise coming from the indoor unit, which is normal in this case.

For additional diagnostic information, refer to the Service Manual.

# DUCTLESS START - UP CHECKLIST - Single Zone

## Installation Data

Site Address: \_\_\_\_\_  
 City: \_\_\_\_\_ State: \_\_\_\_\_ Zip Code: \_\_\_\_\_  
 Installing Contractor: \_\_\_\_\_ Contractor Contact #: ( ) \_\_\_\_\_ - \_\_\_\_\_  
 Job Name: \_\_\_\_\_ Start-up Date: \_\_\_\_\_  
 Distributor: \_\_\_\_\_

## System Details

UNITS	MODEL NO.	SERIAL NO.	CONTROLLER
OUTDOOR UNIT			
INDOOR UNIT A			

Are the outdoor unit and indoor unit compatible? YES: \_\_\_\_\_ NO: \_\_\_\_\_

## Wiring Electrical

Wire Size and Type Used? AWG: \_\_\_\_\_ TYPE: \_\_\_\_\_

Are there any breaks, splices, wire nuts or butt connectors between the outdoor unit and the indoor unit? YES: \_\_\_\_\_ NO: \_\_\_\_\_

Was the wiring from the outdoor unit port to the correct indoor unit verified? YES: \_\_\_\_\_ NO: \_\_\_\_\_

REMARKS: \_\_\_\_\_

## Voltage Check

### Wiring: Single Zone

Outdoor Unit Disconnect	1(L1):GND		Outdoor Unit Terminal Block	1(L1):GND		NOTES: _____ _____ _____
	2(L2):GND			2(L2):GND		
	1(L1):L2(2)			1(L1):2(L2)		
Indoor Unit Voltage Check @ Outdoor Unit	1(L1):GND		Indoor Unit Voltage Check @ Indoor Unit	1(L1):GND		NOTES: _____ _____ _____
	2(L2):GND			2(L2):GND		
	1(L1):2(L2)			1(L1):2(L2)		
	2(L2):3(S)			2(L2):3(S)		

Outdoor Unit Disconnect	1(L1):GND		Outdoor Unit Terminal Block	1(L1):GND		NOTES: _____ _____ _____
	2(L2):GND			2(L2):GND		
	1(L1):L2(2)			1(L1):2(L2)		
Indoor Unit Voltage Check @ Outdoor Unit	1(L1):GND		Indoor Unit Voltage Check @ Indoor Unit	1(L1):GND		NOTES: _____ _____ _____
	2(L2):GND			2(L2):GND		
	1(L1):2(L2)			1(L1):2(L2)		
	2(L2):3(S)			2(L2):3(S)		

## Ductless Start-Up Checklist (CONT)

### Piping

**Leak Check:**

System held 500 psig (max. 550psi) for a minimum of 30 minutes using dry nitrogen. YES: \_\_\_\_\_ NO: \_\_\_\_\_

**Evacuation Method:**

- Was the Triple Evacuation Method used as outlined in the installation manual? YES: \_\_\_\_\_ NO: \_\_\_\_\_
- Was the Deep Vacuum Method used as outlined in the installation manual? YES: \_\_\_\_\_ NO: \_\_\_\_\_
- Did the System Hold 500 microns for 1 hour? YES: \_\_\_\_\_ NO: \_\_\_\_\_
- Does the line set match the diameter of the evaporator connections? YES: \_\_\_\_\_ NO: \_\_\_\_\_
- For Conventional Fan Coils, does the line set match the outdoor unit size? YES: \_\_\_\_\_ NO: \_\_\_\_\_

**Single Zone Piping:**

Has the liquid pipe length been measured and the additional charge calculated? Size: \_\_\_\_\_ Length: \_\_\_\_\_ Charge: \_\_\_\_\_

<b>NOTES:</b>

**NOTE: Final Charge Amount must be recorded!**

PORT	LIQUID SIZE	SUCTION SIZE	LENGTH	CHARGE	NOTES:
A					

### Performance Check

<p><b>For 1:1 Single Zone Systems:</b> Adjust the set-point to create an operational call for the desired testing operation. Allow the system to run for a minimum of 10 min. and record the following details:</p> <p>(Operational data recorded on applicable heads with the wireless remote controller's <b>Point Check</b> function)</p>										
UNIT	SET-POINT	MODE	T1	T2	T3	T4	Tb	Tp	Th	LA/Lr
A										

- NOTE:**
- T1 - Ambient Space Temperature Sensor
  - T2 - IDU Coil Temperature Sensor
  - T3 - Outdoor Coil Temperature Sensor
  - T4 - Outdoor Ambient Temperature
  - Tb - Suction Line Temperature @PMV
  - Tp - Discharge Temperature Sensor
  - Th - IPM Board Temperature
  - LA/Lr - PMV Temperature

### Error Codes

Were there any error codes present at start-up? YES: \_\_\_\_\_ NO: \_\_\_\_\_

Indoor Unit Error Code:		<b>Notes:</b>
Outdoor Unit Error Code:		
Wall Controller:		
24V Interface:		

### Comments:

---



---