



AquaSense®

ZER-TM Series

Automatic Sensor-Operated Gear Driven Type Flushometer for Water Closets and Urinals

Installation, Operation, Maintenance and Parts Manual



Water Closet Battery Models:

ZER6000AV-ONE-TM	1.1 gpf
ZER6000AV-HET-TM	1.28 gpf
ZER6000AV-WS1-TM	1.6 gpf
ZER6000AV-DF-TM	1.1/1.6 gpf

Water Closet Hardwired Models:

ZER6000AV-ONE-TM-HW	1.1 gpf
ZER6000AV-HET-TM-HW	1.28 gpf
ZER6000AV-WS1-TM-HW	1.6 gpf
ZER6000AV-DF-TM-HW	1.1/1.6 gpf

Urinal Battery Models:

ZER6003AV-ULF-TM	0.125 gpf
ZER6003AV-EWS-TM	0.5 gpf
ZER6003AV-WS1-TM	1.0 gpf

Urinal Hardwired Models:

ZER6003AV-ULF-TM-HW	0.125 gpf
ZER6003AV-EWS-TM-HW	0.5 gpf
ZER6003AV-WS1-TM-HW	1.0 gpf

Compliance:

- ADA Compliant
- ASSE 1037/ASME A112.1037/CSA B125.37
- cUPC
- Texas Accessibility Standard (TAS)
- WaterSense Compliant

⚠ WARNING: Cancer and Reproductive Harm - www.P65Warnings.ca.gov

⚠ ADVERTENCIA: Cáncer y daño reproductivo - www.P65Warnings.ca.gov

⚠ AVERTISSEMENT: Cancer et effets néfastes sur la reproduction - www.P65Warnings.ca.gov

LIMITED WARRANTY

All goods sold hereunder are warranted to be free from defects in material and factory workmanship for a period of three years from the date of purchase. Decorative finishes warranted for one year. We will replace at no costs goods that prove defective provided we are notified in writing of such defect and the goods are returned to us prepaid at Sanford, NC, with evidence that they have been properly maintained and used in accordance with instructions. We shall not be responsible for any labor charges or any loss, injury or damages whatsoever, including incidental or consequential damages. The sole and exclusive remedy shall be limited to the replacement of the defective goods. Before installation and use, the purchaser shall determine the suitability of the product for his intended use and the purchaser assumes all risk and liability whatever in connection therewith. Where permitted by law, the implied warranty of merchantability is expressly excluded. If the products sold hereunder are "consumer products," the implied warranty of merchantability is limited to a period of three years and shall be limited solely to the replacement of the defective goods. All weights stated in our catalogs and lists are approximate and are not guaranteed.

NOTICE: READ ENTIRE MANUAL PRIOR TO INSTALLING PRODUCT

Specifications

Sensor Range: 12" to 60" (adjustable)

Voltage: 3 VDC Paralleled [6 "AA" 1.5V Alkaline Cells] or with Optional Hardwired Kit (Supplied Separately)

Operating Water Pressure: 25 psi [172 kPa] (Running); 80 Psi [552 kPa] Max (Static)

Operating Temperature: 35°F to 104°F [2°C to 40°C]

Important Safety Information

- Do not convert or modify this Zurn product. All warranties will be voided.
- All plumbing is to be installed in accordance with applicable codes and regulations.
- Water supply lines must be sized to provide an adequate volume of water for each fixture.
- Flush all water lines prior to making connections.
- Do not use pipe sealant or plumbing grease on any fitting other than the control stop inlet.
- Sensor units should not be located across from each other or in close proximity to highly reflective surfaces.
- Control stop should never be opened to allow flow greater than fixture is capable of evacuating. In the event of valve failure, fixture must be able to handle a continuous flow.

Prior to Installation

- Before installing your flush valve, the items listed below should already be installed on-site:
 - Water closet or urinal fixture
 - Fixture carrier
 - Drain line
 - Water supply line

NOTE: The information in this manual is subject to change at any time without notice. Installations may be performed at different times of construction by different individuals. For this reason, these instructions should be left on-site with the facility or maintenance manager.

Package Contents

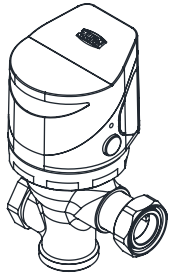

ZER-TM

OR

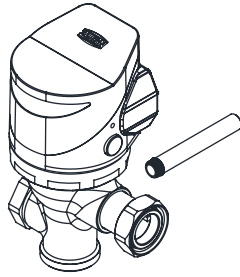

ZER-TM-HW

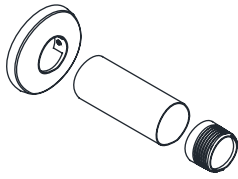

Sweat solder
Connection
with Cast Wall
Escutcheon



Control Stop
with Vandal Cap
(Optional with Aqua Flush)

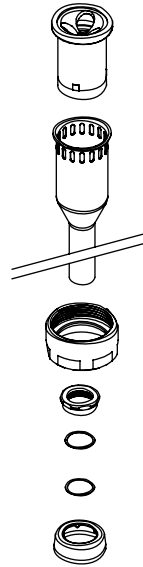

Vacuum Breaker
and Spud
Connection for
Urinal

OR

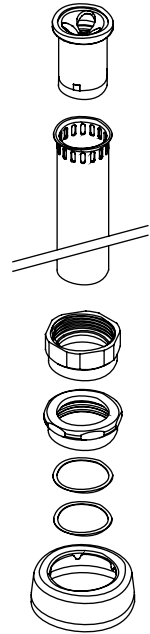

Vacuum Breaker
and Spud
Connection for
Water Closet

Required Tools

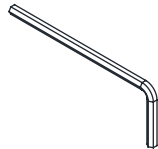

3/32", 5/64"
Hex Key Wrench
(Supplied)

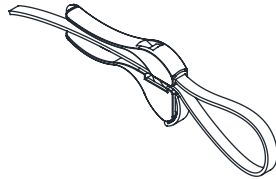

Strap Wrench
(Supplied)

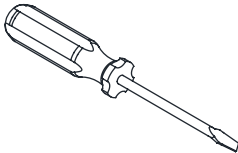

Flat Head
Screwdriver

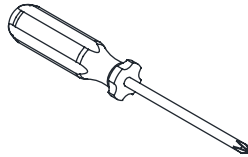

Phillips Head
Screwdriver

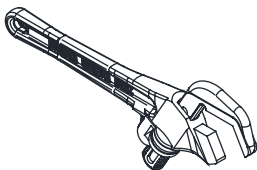

Smooth Jawed
Wrench

Optional Accessories



Magic Magnet
P6900-AT-MAG

Sweat Solder Adapter Installation Instructions

NOTE: Before installation, turn off water supplies to existing fixture and remove flushometer if replacing an existing device.

1. Measure distance from finished wall to the center line of the fixture spud. If necessary, cut water supply pipe 1-1/4" shorter than this measurement. Deburr by chamfering O.D. and I.D of end of water supply pipe.

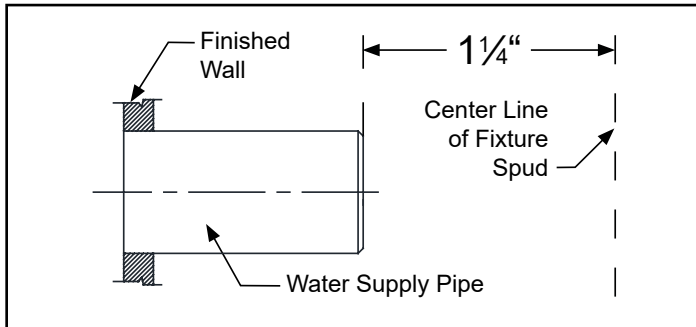

2. Slide threaded sweat solder adapter onto water supply pipe until shoulder stops on end of pipe. Then sweat-solder the adapter to water supply pipe.

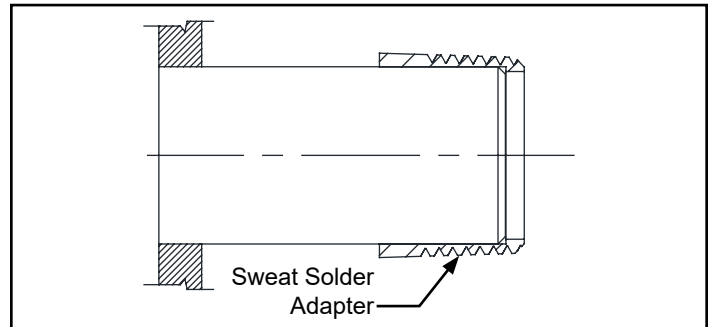

3. Measure distance from finished wall to first thread of sweat solder adapter. If necessary, cut chrome cover tube this length.

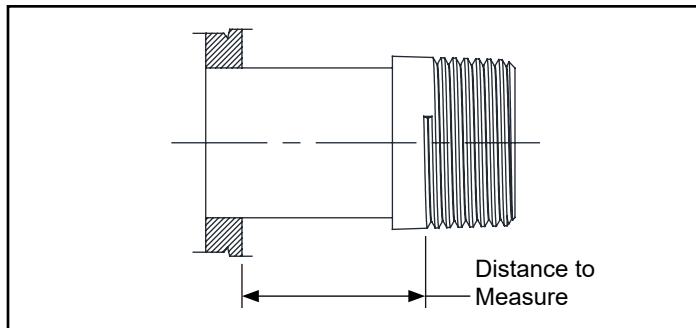

4. Slide wall escutcheon over chrome cover tube and slide both items over water supply pipe. Press wall escutcheon flush against finished wall and tighten set screw with hex wrench (supplied) to secure it in place.

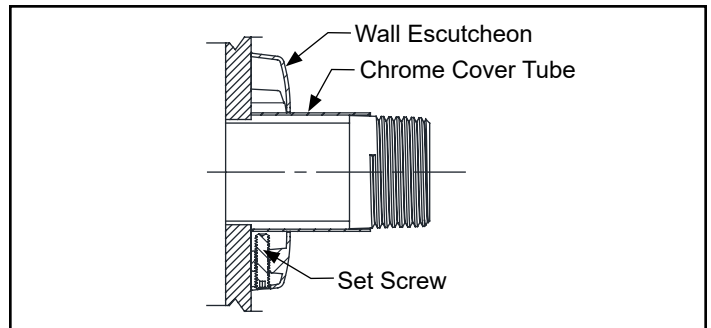

Control Stop Installation Instructions

1. Install control stop assembly by threading it onto water supply pipe and tightening with a smooth jawed wrench. Apply thread sealing compound or pipe tape to male NPT thread on sweat solder adapter only.

Prior to turning on main water supply line ensure all stop valves are closed off tight by using a flathead screwdriver and turning the stop valve adjustment screw clockwise.

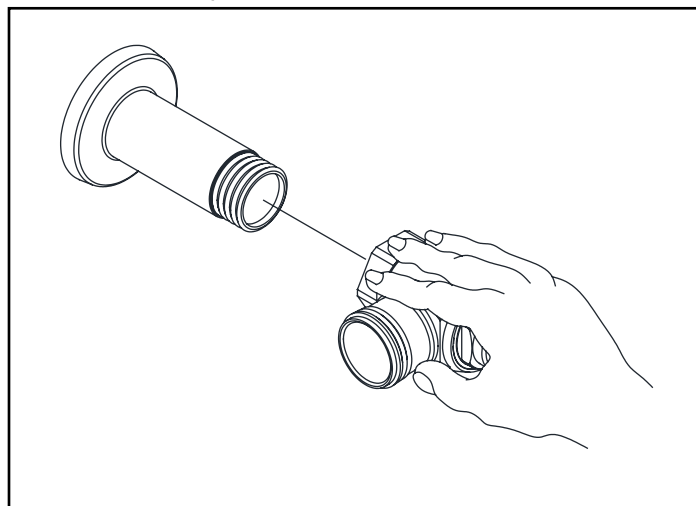

2. When all stop valves are properly connected to the water supply line and water pressure is available open the control stop using a flathead screwdriver and turning the stop valve adjustment screw counterclockwise.

Allow the water supply line to flush any debris or sediment that may be present in the line. Close the control stop once the lines are completely flushed.

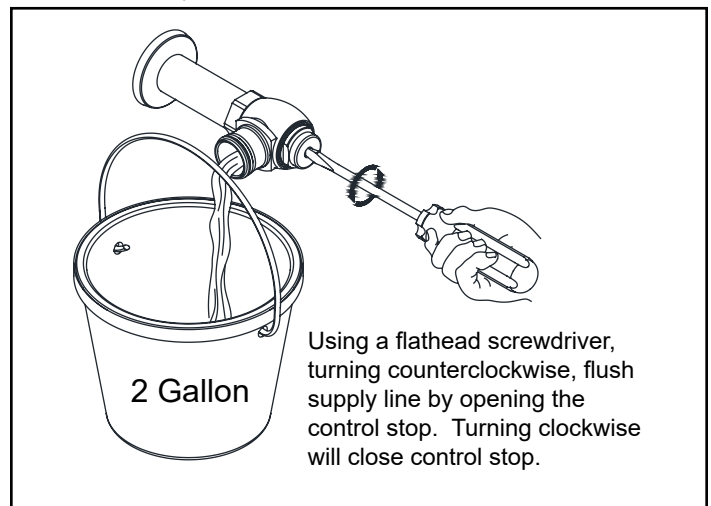

Flush Valve Installation

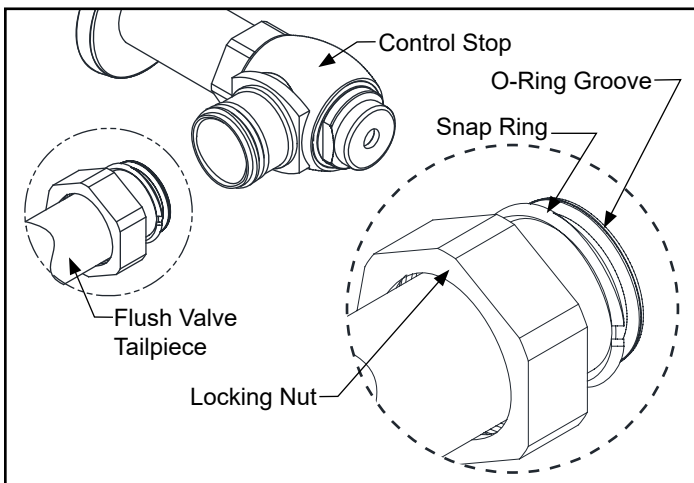

Prior to attaching flush valve tailpiece to control stop, inspect and verify that the O-ring seal is located within the O-ring groove at the tailpiece. Ensure that the locking nut and locking snap ring are also present on the tailpiece.

Lubricate O-ring with water if necessary and insert flush valve tailpiece into the control stop valve. Tighten locking nut using a smooth jawed wrench.

Vacuum Breaker & Flush Connection Installation

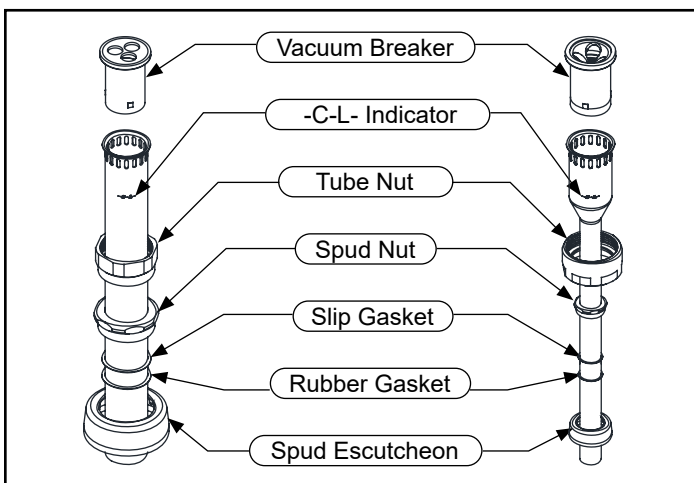

Determine the length of vacuum breaker tube required to join the flush valve and fixture spud, and cut if necessary.

Slide the tube nut, spud nut, slip gasket, rubber gasket and spud escutcheon over the vacuum breaker tube and insert tube into fixture spud. Hand tighten tube nut to valve body and hand tighten spud nut onto fixture spud. Adjust the valve assembly for plumb. Tighten fixture spud nut, vacuum breaker tube nut and locking nut with a wrench.

Adjust and plumb the valve assembly. Tighten all connections with smooth jawed wrench and turn on water supply at the control stop.

DO NOT cut vacuum breaker tube shorter than 6" below the -C-L- indicator mark, as vacuum breaker must be 6" above the fixture. Consult plumbing Codes & Regulations for specific details.

Battery Installation (For both Battery and Hardwired)

1. Turn battery tray screw counterclockwise with the 3/32" hex key wrench until it loose and comes out. Then, slide the battery tray out by hand; the battery screw will stay in the housing.

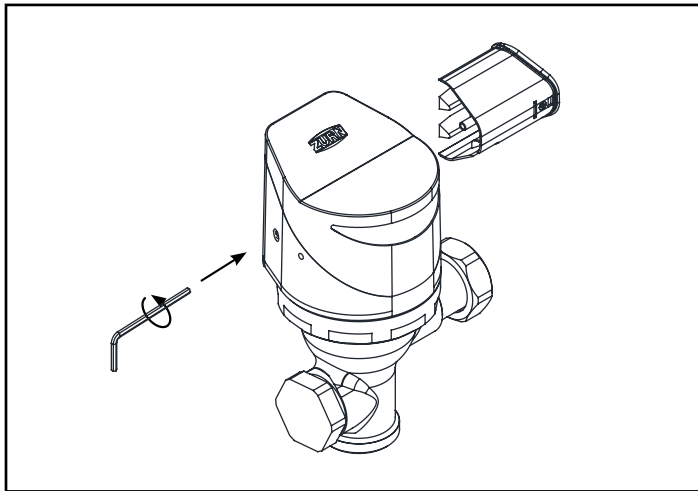

2. As shown, insert 6 (for battery-powered) or 4 (for hardwired) AA Alkaline batteries (supplied) into the battery tray. ZURN recommends standard DURACELL® or RAYOVAC® brands for best fit and function.

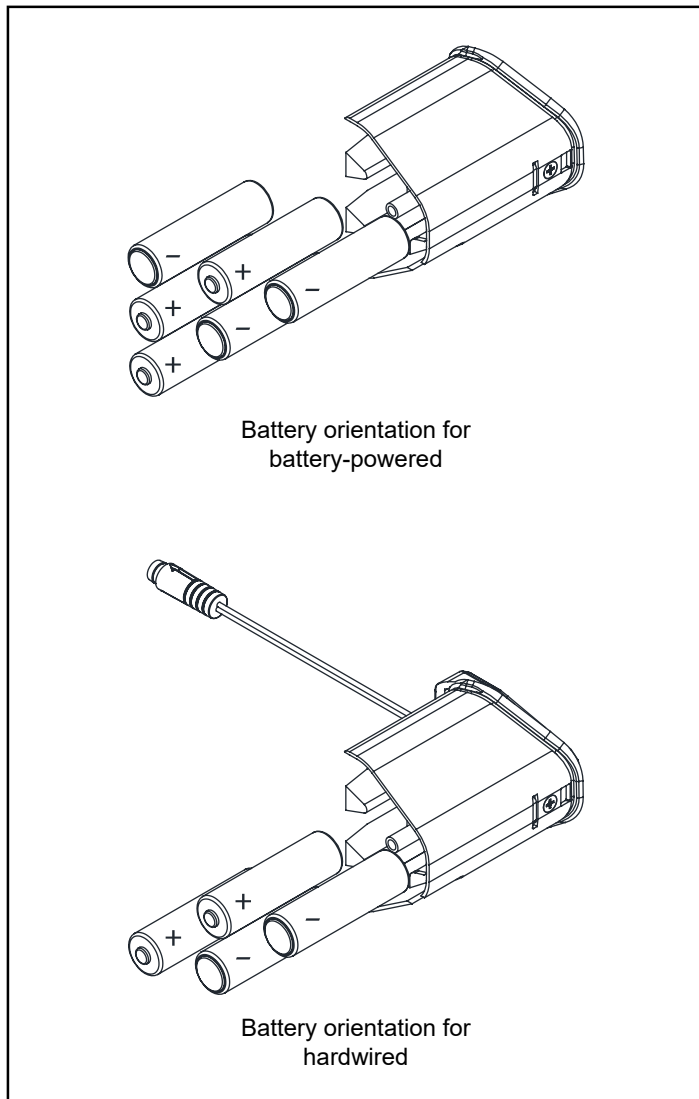

3. Slide the battery tray back into the valve head and apply firm pressure. Turn the 3/32" hex key wrench clockwise to tighten the battery tray screw to a dead-stop and ensure the battery tray is flush with the valve head.

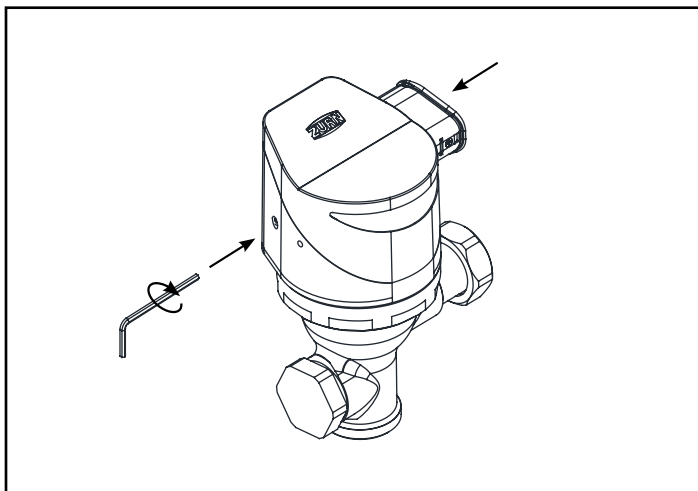

Hardwired Installation (For Hardwired Only)

1. Loosely attach the supplied wall escutcheon onto the wire supply tube, and then route the power supply cable through the wire supply tube.

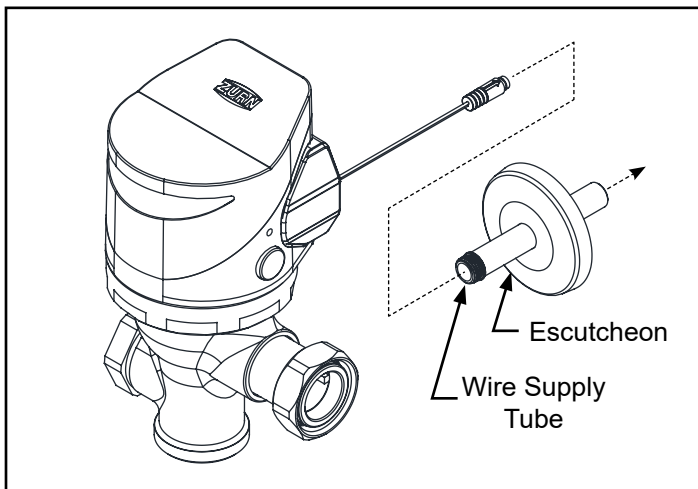

2. Insert both the power supply cable and wire supply tube into a thru-hole on the wall. Hand-tighten the wire supply tube into the battery tray and secure the escutcheon with the set screw.

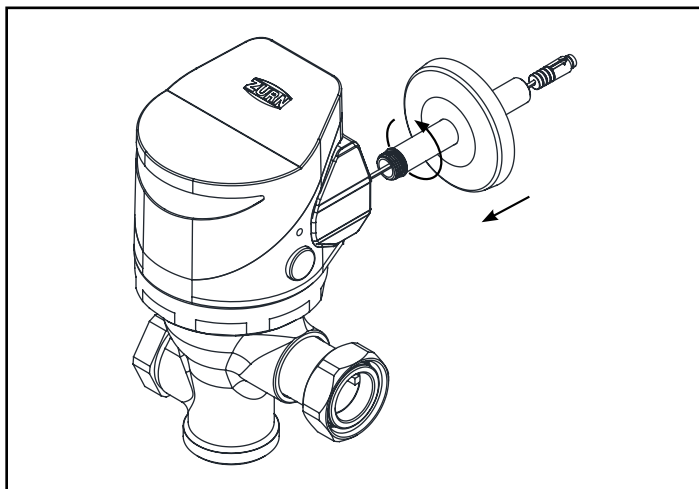

Alternate Hardwired Installation (For Hardwired Only)

Connect Hardwired directly to HW6 Power Converter. (Recommended if one to two flush valves are powered by one HW6.)

1. Using appropriate tools, cut the RED power connector from the end of the power supply cable. Then, strip back the wire insulation by a minimum of 1/4" to expose the bare wire.
2. Secure the RED wire to the Positive (+) screw terminal and the BLACK wire to the Negative (-) screw terminal on the HW6.

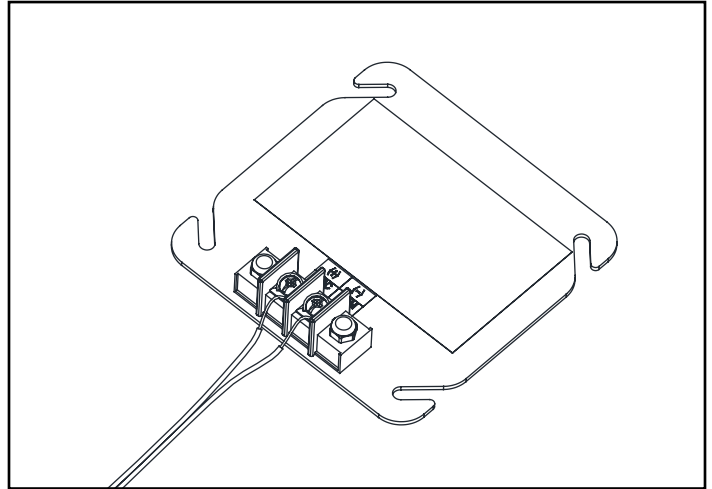
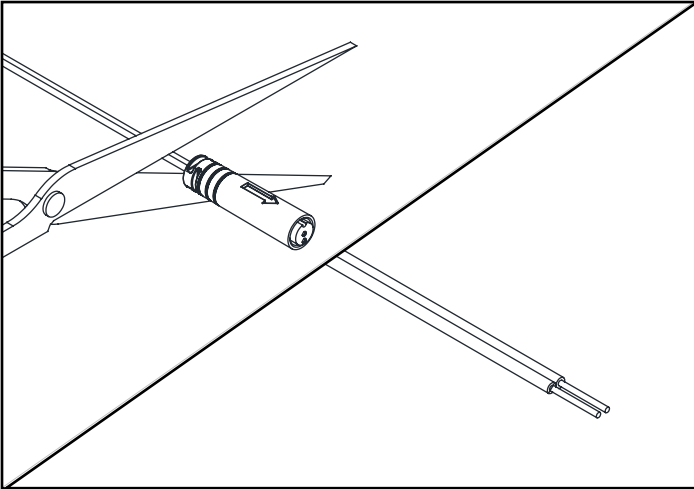

Optional -MJ Junction Box (Recommended when three or more flush valves utilize one HW6)

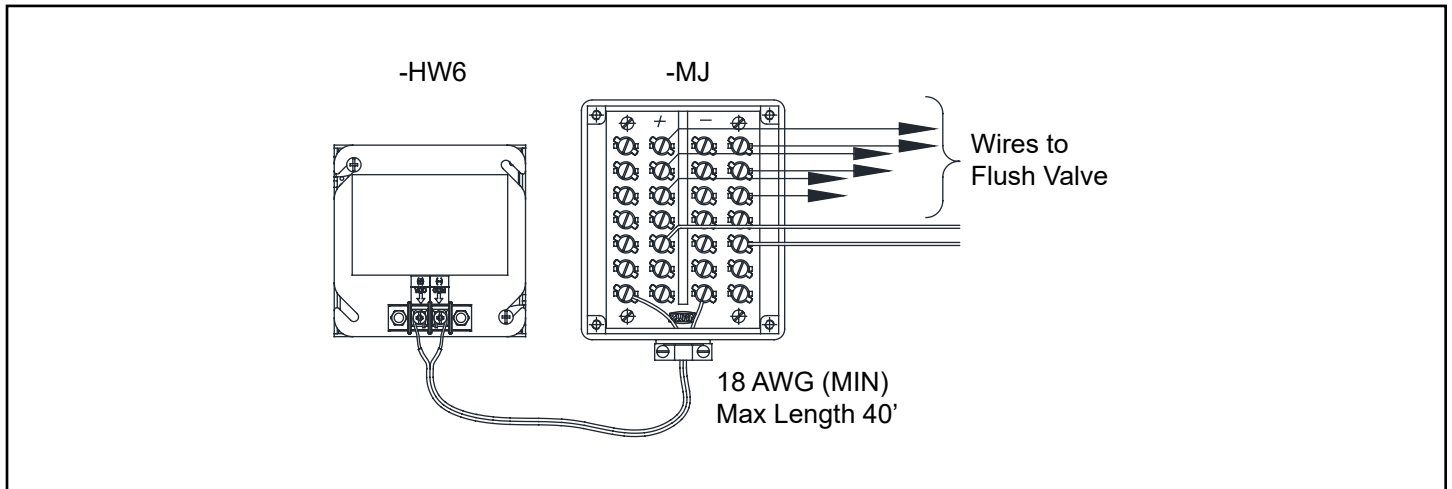

Sensor Angle Adjustment (when necessary)

1. Turn off control stop using a flat head screwdriver turning clockwise. Afterward, utilize the manual override button to flush water out of the flush valve.
2. Before loosening the locking ring, ensure that both the strap wrench and locking ring are completely dry. This will optimize the grip of the strap wrench on the locking ring.

Use tape or a marker to mark the original position of the locking ring in relation to the valve body.

Using the supplied strap wrench, loosen the locking ring on the valve head by turning it counter-clockwise. If the strap wrench is unable to loosen the locking ring, you may use a large wrench on the flats of the locking ring to loosen it.

3. Adjust the sensor angle by rotating the valve head
4. Before tightening the locking ring, ensure that both the strap wrench and locking ring are completely dry. This will optimize the grip of the strap wrench on the locking ring.

Using the supplied strap wrench, tighten the locking ring back to its original position by turning it clockwise.

5. Turn the control stop back on by turning counter-clockwise using a flat head screwdriver.

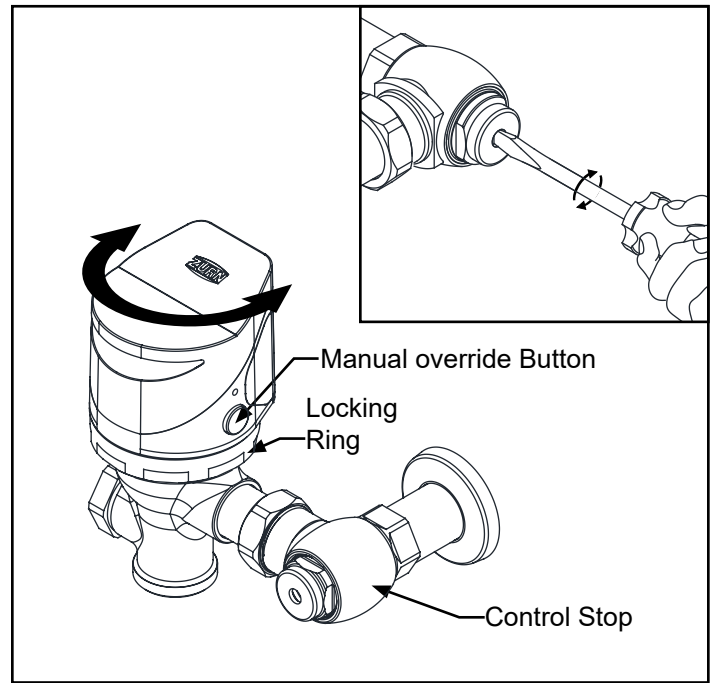

Diaphragm Replacement and Cleaning (when necessary)

1. Turn off control stop using a flat head screwdriver turning clockwise. Afterward, utilize the manual override button to flush water out of the flush valve.
2. Before loosening the locking ring, ensure that both the strap wrench and locking ring are completely dry. This will optimize the grip of the strap wrench on the locking ring.

Use tape or a marker to mark the original position of the locking ring in relation to the valve body.

Using the supplied strap wrench, loosen the locking ring on the valve head by turning it counter-clockwise. If the strap wrench is unable to loosen the locking ring, you may use a large wrench on the flats of the locking ring to loosen it.

3. Remove the existing diaphragm kit from the manifold stem. Thoroughly wash the diaphragm and orifice using water.

Install the cleaned diaphragm back into the valve body, ensure that the orifice is facing the correct orientation. For the correct orifice orientation, Refer to the retrofit installation instruction section.

If the issue persists after cleaning, proceed to step 3B.

- ⚠** Do not to damage or enlarge orifice. Doing so will result in incorrect flush rate.

- 3B. Remove the existing diaphragm kit from the manifold stem. If the o-rings show signs of wear or damage, replace them with the new ones provided in the diaphragm repair kit.

Install a new diaphragm kit (with matching flow rate) into the valve body, ensure that the orifice is positioned opposite the control stop. Take care to align it properly.

Note that unless the Volume Control Ring is missing or broken, there is no need to replace it.

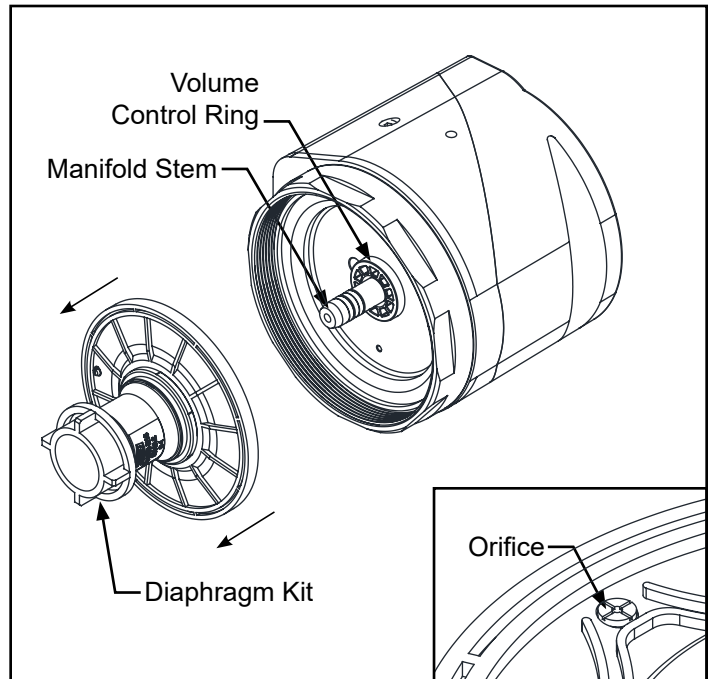

4. Place the valve head with the diaphragm kit back onto the valve body. Ensure that both the strap wrench and locking ring are dry for a better grip. Tighten the locking ring to its original position using the supplied strap wrench by turning it clockwise.
5. Turn the control stop back on by turning counter-clockwise using a flat head screwdriver.

Retrofit Installation Instruction

1. Turn off the control stop by turning it clockwise using a flat head screwdriver. Then, use the electronic or manual override button or manual handle to flush the water out of the flush valve.

2. Remove the existing valve cap/head and diaphragm kit from the valve body to achieve the desired state shown on the top right.

3. (FOR ULF UNIVERSAL KIT ONLY)

Loosen the tailpiece nut from the control stop and slide the tailpiece out of the control stop. If the valve body does not have matching tailpiece tabs as shown one the right, carefully insert the tailpiece into the control stop, tighten the tailpiece nut, and proceed to Step 4.

If tailpiece tabs are present, press the Flow Restrictor into the tailpiece, aligning the tabs with the pockets on the Flow Restrictor. Carefully insert the tailpiece into the control stop and tighten the tailpiece nut.

4. Ensure the Volume Control Ring is installed on the manifold stem. Slide the diaphragm kit into the valve body, orienting the orifice opposite the control stop as depicted in Figure on the bottom.

5. Install the valve head and diaphragm kit onto the valve body. Rotate the valve head so that the sensor window faces outward. Refer to the Sensor Angle Adjustment section for additional details if needed.

6. Before tightening the locking ring, ensure that both strap wrench and locking ring are completely dry. This will optimize the grip of the strap wrench on the locking ring.

Hand tighten the locking ring onto the valve body. If the locking ring will not thread onto the valve body, go to the Locking Ring Change Section. Finish tightening the locking ring using the strap wrench. Turn the locking ring at least 1/3 of a turn with the strap wrench.

7. (if applicable)

Remove the Manual Handle. Place the Handle Cap Seal in the Handle Cap and torque the handle cap in place.

8. Slowly turn the control stop counter-clockwise using a flat head screwdriver to turn it on, and check for any leaks. If leaks occur, tighten the locking ring further.

Proceed to the Battery Installation section to power on the unit and check for leaks again after flushing the valve.

If leaks are still present, you may use a large wrench on the flats of the locking ring to tighten it.

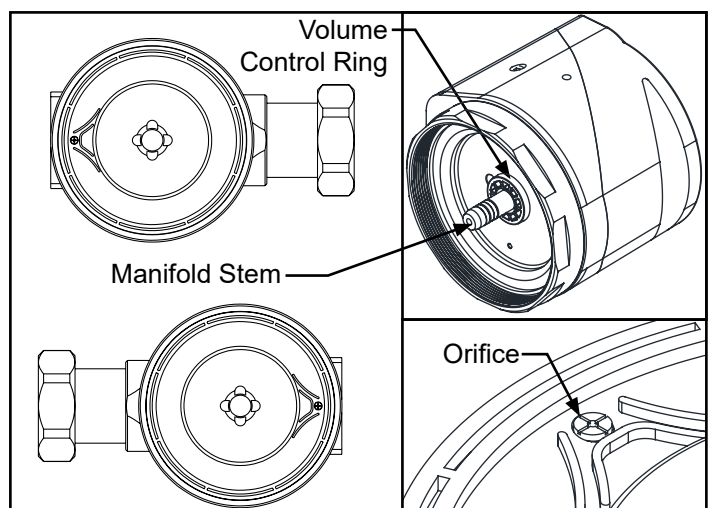
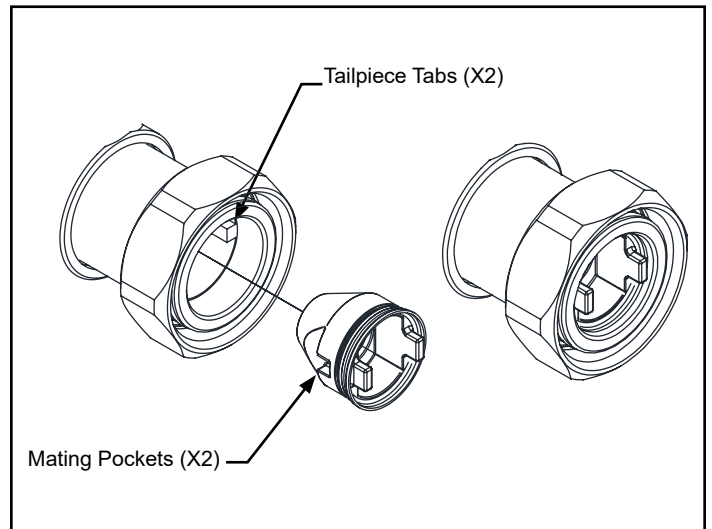
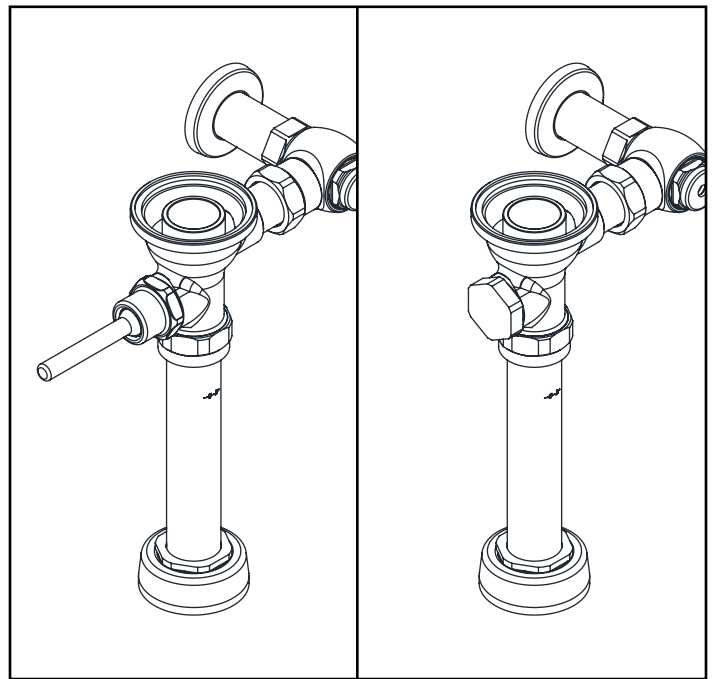

Sensor Range Adjustment (when necessary)

To ensure optimal performance in various restroom environments, each ZER-TM is initially calibrated at the factory. However, in situations where there is low light or high reflectivity, it might be necessary to make adjustments to the calibration distance of the unit. This can be done using a Magic Magnet (P6900-AT-MAG).

Follow the steps outlined below to re-calibrate the ZER-TM using a Magic Magnet (P6900-AT-MAG):

1. Stand at the desired calibration distance:
 - ~28" from the sensor in a water closet application.
 - ~22" from the sensor in a urinal application.
2. Place Magic Magnet to the right of the ZER-TM's lens within indicated area. Hold the Magic Magnet in that position until the user LED lights up.
3. Maintain the position of the Magic Magnet until the user LED starts blinking. Once the blinking begins, remove the Magic Magnet and allow the user LED to blink 10 times while remaining in the same position. A quick double-blink of the user LED indicates that the calibration process is complete.
4. To verify the new calibration distance, step away from the unit for 5 seconds. Then return to the exact position at which it was calibrated and observe the user LED. If the user LED blinks, it indicates that the calibration distance has been successfully calibrated.

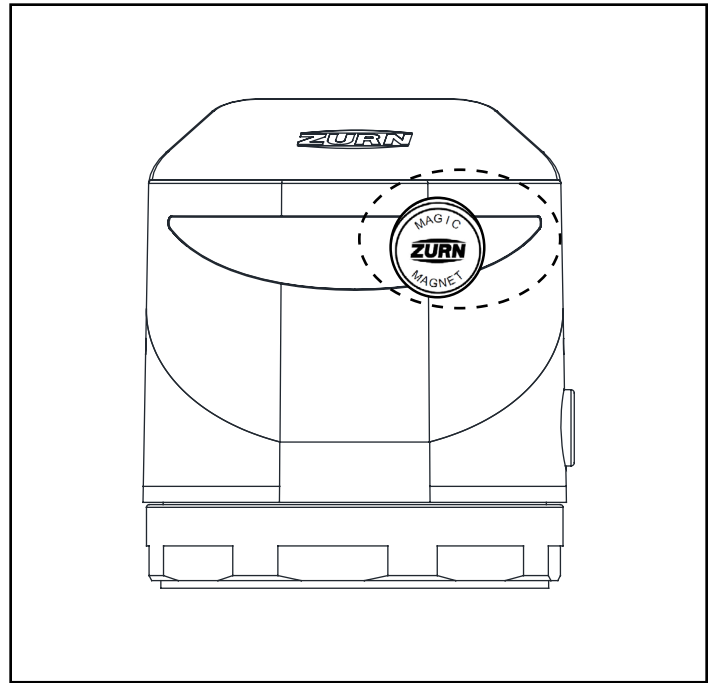

Note: To ensure proper functionality, make sure the calibration distance in water closet applications prevents the sensor from detecting the stall door. Verify this by closing the door for 10 seconds, then opening it. If the flush valve doesn't activate, the calibration distance is suitable. Otherwise, recalibrate to a closer distance using the magnet.

Courtesy Flush & Battery Detection Settings (when necessary)

A courtesy flush can be enabled for the ZER-TM flushometer where the valve will automatically flush at a specified interval based on customer preference.

- Using a 3/32" hex key wrench, turn counter-clockwise to loosen the internal set screws at the indicated locations. Once the set screws are fully retracted, carefully detach the Valve Cap without disconnecting the connector within the valve head.

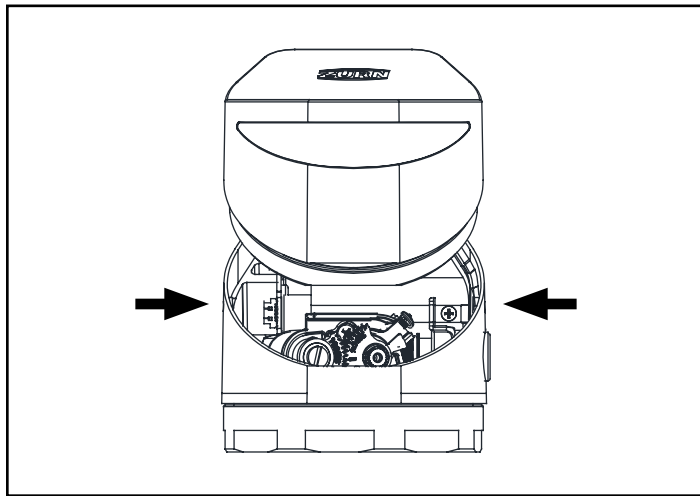

- To access the DIP switches, remove the plastic boot located on the underside of the electronic housing.

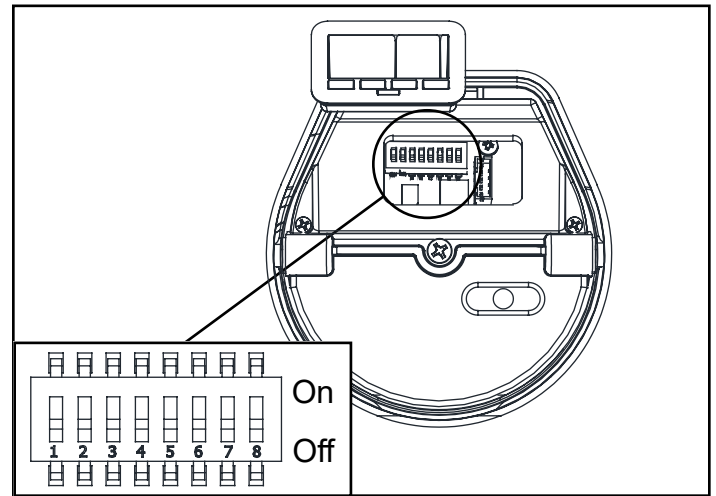

- Adjust the courtesy flush interval by manipulating DIP switches #2 and #3 according to the table provided below:

Courtesy Flush Interval	DIP switch #2	DIP switch #3
Disabled (Default Setting)	OFF	OFF
24 hours	OFF	ON
48 hours	ON	OFF
72 hours	ON	ON

- Adjust the battery detection function by manipulating DIP switches #8 according to the table provided below:

Battery detection	DIP switch #8
Enabled (Default Setting)	OFF
Disabled	ON

- Reinstall the plastic boot and position the connectors and harness cable in the vacant area near the motor. Then, follow the initial step to locate the internal set screws and tighten them clockwise to secure the valve cap.

Dual Flush User Guide (For ZER6000AV-DF-TM Only)

- The Dual Flush model supplies flush volumes of 1.1 and 1.6 gallons per flush. When a user is present for less than 60 seconds, the valve will flush with 1.1 gallons of water. When a user is present for over 60 seconds, the valve consumes 1.6 gallons of water. A user must be present for a minimum of 8 seconds in order to trigger a flush.
- The Dual Flush model must be paired with a fixture with a flush volume range that includes 1.1 to 1.6 gallons per flush. For a list of recommended bowls, please refer to our website, www.zurn.com, or speak with your local Zurn rep.

Care and Cleaning Instruction

- Do not use any abrasive or chemical cleaners to clean the flushometer.
- The suggested cleaning of chrome plated surfaces is simply to clean them with mild soap and water, then dry. Commercial cleaning compounds are never recommended.
- Upon cleaning other areas of the restroom, be sure the sensor lenses are protected from other cleaning chemicals/solvents to prevent potential damages to the sensor and/or electronics.
- Valves used in installations subject to shut down because of cold and freezing conditions should be maintained in the following manner. After the main supply has been shut off and the water drained from the system, remove the stop valve cap and stop valve internals to allow the water to drain from the flush valve itself.

Trouble Shooting Guide

Problem	Indicator	Cause	Corrective Action
Flush valve does not flush.	No water flushed.	Stop valve is closed	Open stop valve
	Sensor flashes 5 times in quick succession	Flush cycle did not complete	Contact Customer Service for further instruction
	No sensor light	Batteries not making contact	Remove and reinstall batteries correctly, or replace batteries. See Battery installation for reference.
		Critically low battery voltage	
	Sensor flashes once every 5 seconds	Low battery voltage indication	
	Sensor flashes every 30 seconds	Continuous user detection of object within sensor range	Recalibrate. See Sensor Range adjustment section for reference.
	Sensor flashes rapidly	Battery Powered: Batteries installed incorrectly.	Remove and reinstall batteries correctly. See Battery installation for reference.
		Hardwired: Backup batteries installed incorrectly	Remove and reinstall batteries correctly. See Battery installation for reference.
		Hardwired: Backup Battery not detected.	Install backup batteries, or reference courtesy flush & battery detection settings section to turn off backup battery detection.
	Sensor detects user, three slow flashes & two quick flashes, but fail to flush upon exiting sensor range	User/object still in sensor field	Identify and remove any user from sensor field Reduce sensor range distance (see Sensor Range Adjustment instructions)
		Battery power level too low to activate flush valve	Replace batteries. See Battery Installation for reference.
		Dirty sensor lens	Clean sensor lens with warm water and mild soap until free of debris
		Loose or damaged wire harness	Inspect wire harness and connection between electronics and motor
	User not detected; no LED flashes.	Sensor range may need to be adjusted	Increase sensor range distance (see Sensor Range Adjustment instructions)
		Flush valve is aimed at an angle.	Rotate flush valve head to be perpendicular to wall. See Sensor Angle Adjustment section for adjusting the flush valve head.
Manual override button does not initiate a flush.	Stop valve is closed / turned off.	Turn on stop valve.	
	MOB does not depress	Contact Customer Service.	
Valve does not evacuate fixture	Insufficient volume of water to adequately siphon fixture.	Stop valve is not open enough.	Open stop valve for desired volume of water.
		Insufficient volume or pressure at supply.	Increase incoming water supply pressure to minimum 25psi.
		Insufficient volume for installed fixture	Contact Customer Service.
	Valve shuts off too quickly or short flushes.	Damaged or punctured diaphragm.	Install new diaphragm replacement kit. (See Diaphragm Replacement and Cleaning Section for replacement instruction)
		Enlarged by-pass orifice.	Install new diaphragm replacement. (See Diaphragm Replacement and Cleaning Section for replacement instruction)
		Diaphragm kit is not matched to the fixture.	Install new diaphragm replacement kit. (See Diaphragm Replacement and Cleaning Section for replacement instruction)

Trouble Shooting Guide

Problem	Indicator	Cause	Corrective Action
Valve is flushing too long or not shutting off.	High water delivery or continuous flow.	By-pass orifice is plugged or partially plugged.	Examine by-pass orifice and clean if necessary being certain not to enlarge orifice opening. (See Diaphragm Replacement and Cleaning Section for cleaning instruction)
Water splashes out of fixture.	Water splashes onto floor during flush cycle.	Supply volume is too high.	Slowly close the control stop to lower water pressure.
		Mineral accumulation on vortex or spreader holes of fixture.	Remove the mineral build up.
Flush is not considered quiet.	Flush is loud.	Control stop may not be adjusted for quiet operation.	Adjust the control stop for quiet operation keeping in mind the fixture evacuation requirements.
		Fixture may be contributing to noise.	Check noise created by fixture by placing a cover over the bowl opening to separate valve noise from bowl noise. If it is determined the fixture is too noisy, consult with fixture manufacturer.
		Piping system may be source of noise.	High pressure in the system can sometimes be controlled by the stop valve. Other sources of noise may be the absence of air chambers and shock arrestors, loose pipes, improper size pipes, etc. In these cases, the building engineer should be consulted.
Valve leaking near valve head.	Water droplets seen between valve head and valve body.	Locking ring not tight.	Tighten locking ring. See Sensor Angle Adjustment section for reference.
Valve flushed with no user present	Valve flushed with no user present	Highly reflective environment	Re-calibrate sensor range - see Sensor Range Adjustment section
		Sensor range set too far; picking up other objects	
		Flush valve may be configured to exchange the water in the trap-way at every [24 / 48 / 72] hours after no usage (default is OFF).	See Courtesy Flush Battery Detection Settings for instructions on changing dipswitch settings to achieve desired trap exchange timing.

For further assistance with troubleshooting, visit <http://www.zurn.com/>

ZER-TM Series Repair Kits

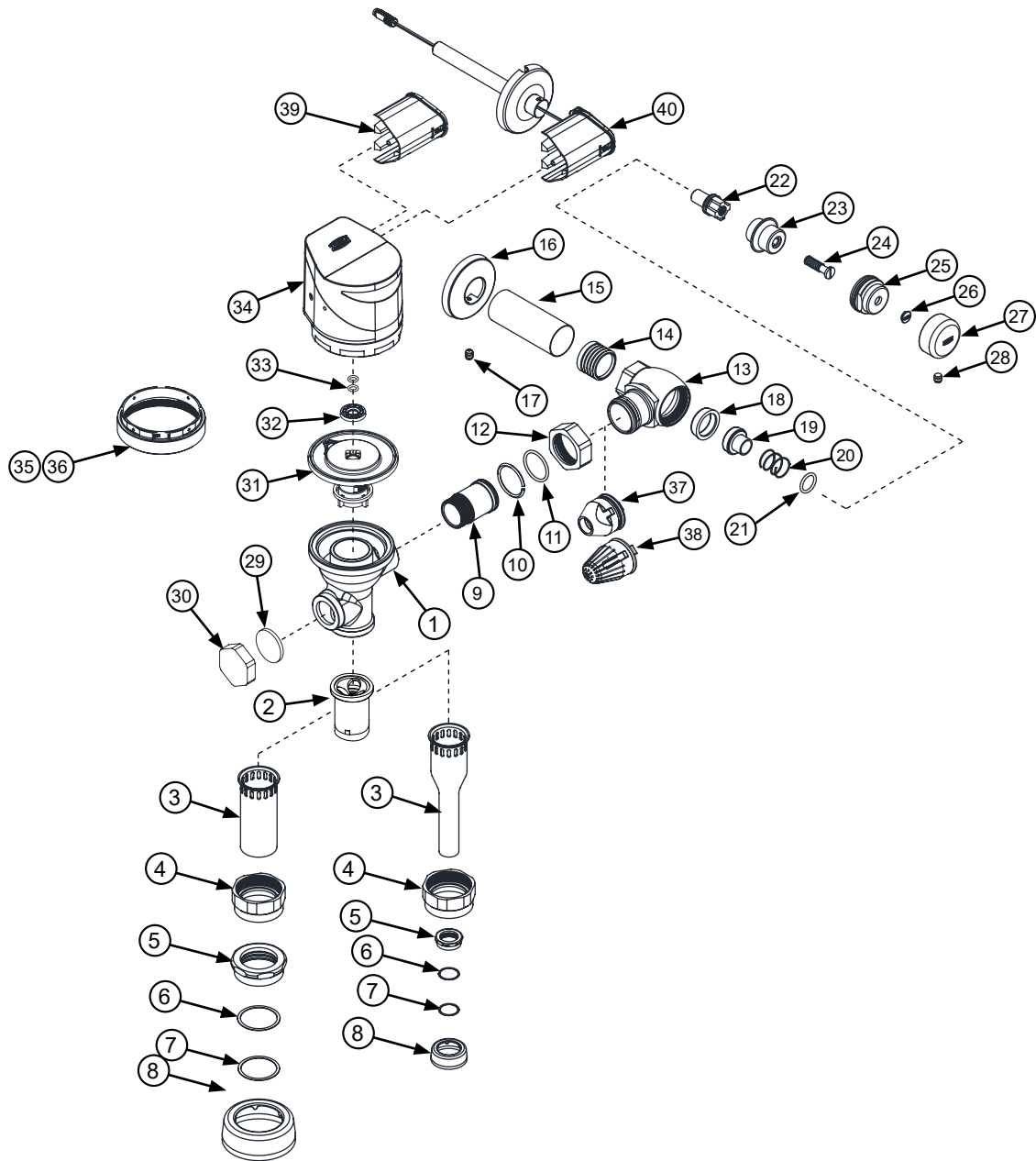

Part Identification

- | | | |
|----------------------------|---|--------------------------------------|
| 1. Valve Body | 16. Cast Wall Escutcheon | 31. Diaphragm Kit |
| 2. Vacuum Breaker Duckbill | 17. Setscrew for Cast Wall Flange | 32. Volume Control Ring |
| 3. Vacuum Breaker Tube | 18. Piston Seal | 33. Manifold Stem O-Ring |
| 4. Vacuum Breaker Tube Nut | 19. Piston | 34. ZER-TM Valve Head |
| 5. Spud Nut | 20. Stop Spring | 35. Locking Ring |
| 6. Spud Friction Washer | 21. Guide O-Ring | 36. *Sloan® Locking Ring |
| 7. Spud Sleeve | 22. Piston Guide | 37. Filter |
| 8. Spud Escutcheon | 23. Guide Holder | 38. Flow Restrictor |
| 9. Tailpiece | 24. Adjusting Screw | 39. Battery Tray for TMFV |
| 10. Snap Ring | 25. Stop Cap | 40. Battery Tray for TMFV - Hardwire |
| 11. Tailpiece O-Ring | 26. Snap Cap Screw Cover | |
| 12. Locking Nut | 27. Vandal Resistant Control Stop Cover | |
| 13. Stop Body | 28. Setscrew for Control Stop Cover | |
| 14. Sweat Solder Adapter | 29. Handle Cap Seal | |
| 15. Supply Cover Tube | 30. Handle Nut | |

Service Parts

Control Stop Repair Kit and Parts	Product No.
Control Stop Repair Kit for 1" and 3/4", Items 18-24	P6000-D-SD
Seal Seat for 1" and 3/4", Item 18	P6000-D42
VP Control Stop Repair Kit for 1" and 3/4", Items 18-24	P6000-D-VP
Sweat Solder Connection with Cast Wall Flange, Items 14-16	P6000-YBYC

Adjustable Tailpieces	Product No.
Adjustable Tailpiece for Standard Flush Valve, Items 9-11	P6000-J1
Tailpiece Coupling Assembly, Items 10-12	P6000-K
Tailpiece Locking Ring, Item 10	P6000-C30
Tailpiece O-Ring, Item 11	P6000-C31
Coupling Nut, Item 12	P6000-C32
Filter, (Full Valve Only), Item 37	P6000-FA
Flow Restrictor, (Universal ULF PERK6203-FA Kit Only), Item 38	PERK6203-FA

Flush Connections and Spud Coupling Kits	Product No.
Vacuum Breaker Repair Kit, Item 2	P6000-B
Spud Coupling Assembly for Water Closet, Items 5-8. Specify size.	P6000-H
Spud Coupling Assembly for Urinal, Items 5-8. Specify size.	P6003-H

ZER-TM Valve Head Repair Kit and Parts	Product No.
Locking Ring, Item 35	PER6000-M-RING
*Sloan® Locking Ring, Item 36	PER6000-M-RING-S
Valve Head, (1.1 gpf), Item 34	PERK6000-L-1.1
Valve Head, (1.28 gpf), Item 34	PERK6000-L-1.28
Valve Head, (1.6 gpf), Item 34	PERK6000-L-1.6
Valve Head, (1.6/1.1 gpf), Item 34	PERK6000-L-1.6/1.1
Valve Head, (0.125gpf), Item 34	PERK6003-L-0.125
Valve Head, (0.5 gpf), Item 34	PERK6003-L-0.5
Valve Head, (1.0 gpf), Item 34	PERK6003-L-1.0
*Valve Head for Sloan®, (1.1 gpf), Item 34	PERK6000-L-1.1-S
*Valve Head for Sloan®, (1.28 gpf), Item 34	PERK6000-L-1.28-S
*Valve Head for Sloan®, (1.6 gpf), Item 34	PERK6000-L-1.6-S
*Valve Head for Sloan®, (1.6/1.1 gpf), Item 34	PERK6000-L-1.6/1.1-S
*Valve Head for Sloan®, (0.125 gpf), Item 34	PERK6003-L-0.125-S
*Valve Head for Sloan®, (0.5 gpf), Item 34	PERK6003-L-0.5-S
*Valve Head for Sloan®, (1.0 gpf), Item 34	PERK6003-L-1.0-S
Battery Tray for TMFV, Item (39)	PER6000-L-TM-BATT
Battery Tray for TMFV, -Hardwire Item (40)	PER6000-L-TM-BATT-HW

ZER-TM Diaphragm Repair Kit	Product No.
Closet Repair Kit - (1.1, 1.28, 1.6, 1.6/1.1 gpf), Item 31-33	PER6000-EC
Urinal Repair Kit - (0.125 gpf), Item 31-33	PER6003-EU-ULF
Urinal Repair Kit - (0.5, 1.0 gpf), Item 31-33	PER6003-EU

* Sloan is a registered trademark of Sloan Valve Company. Sloan and the Sloan products listed are not associated with Zurn or Zurn's products.

The brands and product names listed may be subject to the trademark rights of their respective owners. Use of the brands and names is for identification purposes only and does not imply affiliation with or endorsement by Zurn. Zurn provides this information for general cross reference purposes only. Zurn makes no representations regarding the quality, comparability, or compatibility of any competitor products listed. All information is subject to change without notice.

Rev. E | Date: 6/13/2025 | C.N. No. 146959 | Prod./Dwg. No. FV838

Patent zurn.com/patents

US 1.855.0NE.ZURN CANADA 1.877.892.5216

ZURN.COM

by **zurn ELKAY** Water Solutions