

## EMAWX

(formerly EMA4X)

### Evaporator Coils for Manufactured Housing using R-410A Refrigerant

**IN THE U.S. THIS PRODUCT IS FOR SERVICE AND WARRANTY ONLY.**

## Installation Instructions

**IMPORTANT:** The EMAWX replaces the EMA4X model and in the United States is only available for service and warranty use.

**NOTE:** Read the entire instruction manual before starting the installation.

### SAFETY CONSIDERATIONS

Improper installation, adjustment, alteration, service, maintenance, or use can cause explosion, fire, electrical shock or other conditions which may cause death, personal injury or property damage. Consult a qualified installer, service agency, or your distributor or branch for information or assistance. The qualified installer or agency must use factory-authorized kits or accessories when modifying this product. Refer to the individual instructions packaged with the kits or accessories when installing.

Follow all safety codes. Wear safety glasses, protective clothing and work gloves. Use quenching cloths for brazing operations. Have fire extinguisher available. Read these instructions thoroughly and follow all warnings or cautions attached to the unit. Consult local building codes and the current editions of the National Electrical Codes (NEC) NFPA 70.

In Canada, refer to the current editions of the Canadian Electrical Code CSA C22.1.

Recognize safety information. This is the safety-alert symbol . When you see this symbol on the unit and in instructions or manuals, be alert to the potential for personal injury.

Understand the signal words DANGER, WARNING and CAUTION. These words are used with the safety-alert symbol. DANGER identifies the most serious hazards which will result in severe personal injury or death. WARNING signifies hazards which could result in personal injury or death. CAUTION is used to identify unsafe practices, which may result in minor personal injury or product and property damage. NOTE is used to highlight suggestions which will result in enhanced installation, reliability, or operation.

### WARNING

#### ELECTRICAL SHOCK HAZARD

Failure to follow this warning could result in personal injury or death. Before installing, modifying or servicing system, always turn off main power to system. There may be more than one disconnect switch. Lock out and tag switch with a suitable warning label.

### CAUTION

#### ENVIRONMENTAL HAZARD

Failure to follow this caution may result in environmental damage. Federal regulations require that you do not vent refrigerant to the atmosphere. Recover during system repair or final unit disposal.

### CAUTION

#### CUT HAZARD

Failure to follow this caution may result in personal injury. Sheet metal parts may have sharp edges or burrs. Use care and wear appropriate protective clothing and gloves when handling parts.

### CAUTION

#### UNIT OR PROPERTY DAMAGE HAZARD

Failure to follow this caution may result in product or property damage. Take precautions to ensure that aluminum tubes do not come in direct contact or allow for condensate runoff with dissimilar metal. Dissimilar metals can cause galvanic corrosion and possible premature failure.

### WARNING

#### PERSONAL INJURY HAZARD

Failure to follow this caution may result in personal injury. This coil contains Nitrogen precharge of 15 PSIG. Release of this pressure through the center of the rubber plugs is required before removing the plugs.

### INTRODUCTION

It is important that the Blower and Duct System be properly sized to allow the system to operate at full capacity. Poorly designed systems will not give satisfactory cooling or economy. They may even shorten the service life of the compressor in the outdoor unit.

**IMPORTANT:** Nitrogen can leak out through the needle pierce hole in the plugs. This does not indicate a leaking coil nor warrant return of the coil.

### INSTALLATION

EMAWX coils are designed to be used within a gas or electric downflow furnace certified for use in manufactured homes (mobile homes). These coils are suitable for use in upflow cooling configurations with upflow electric furnaces, but are not qualified for use with traditional upflow gas and oil furnaces (nuisance tripping of heat exchangers limits may result). EMAWX Coils are for use on the outlet (supply) side of gas or oil furnaces only. This reduces condensate formation in the furnace heat exchanger during the cooling cycle.

1. Disconnect power to furnace.
2. Remove furnace front access door(s).
3. Remove furnace inner sheet metal shield.
4. Remove knockouts from furnace cabinet and inner shield.

5. Assemble the two halves of the coil header plate over the coil tubes and fasten together using supplied screws.
6. Slide rubber grommets into place around coil tubes and into coil header plate holes.
7. Position rails inside furnace as shown in Fig. 1. Slide coil into furnace, nesting drain pan inside rails.
8. Align furnace inner shield (removed earlier) with coil header plate so that the refrigerant tubes fit through the knockouts. Fasten each corner of shield to header plates using supplied screws.

**NOTE:** Some furnaces require that the flange at the top of the upper coil header plate be removed or bent down flat in order to fit the furnace inner shield.

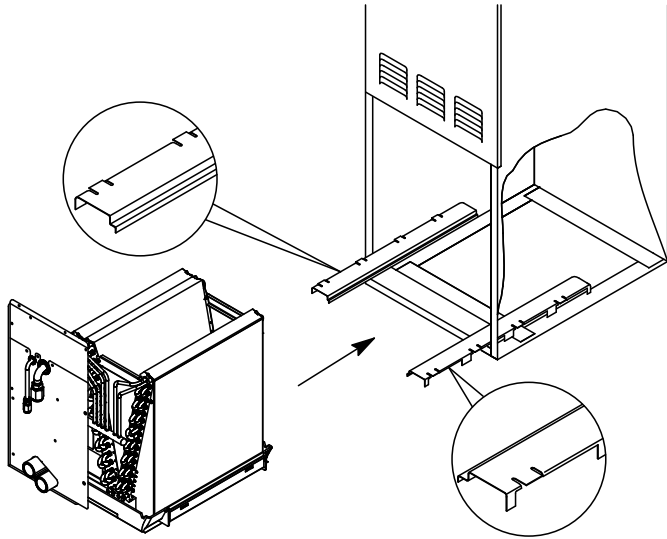

Fig. 1 – Rails

A05435

**! CAUTION**

**PROPERTY DAMAGE HAZARD**

Failure to follow this caution may result in property damage. A field fabricated auxiliary drain pan, with a separate drain is **REQUIRED** for all installations over a finished living space or in any area that may be damaged by overflow from a restricted main drain pan.

**Refrigerant Line Connections**

**! WARNING**

**PERSONAL INJURY HAZARD**

Failure to follow this warning could result in personal injury. Wear eye protection. Coil is factory charged with 15 psi nitrogen. The coil is under pressure and TXV screen is in place behind liquid line plug. **DO NOT** remove liquid line plug first; always remove the suction line plug first to depressurize the coil.

Size and install refrigerant lines according to information provided with outdoor unit. Coil connection tube sizes are shown in Table 1. Route refrigerant lines to the coil in a manner that will not obstruct service access to the unit or removal of the filter.

**! CAUTION**

**UNIT OR PROPERTY DAMAGE HAZARD**

Failure to follow this caution may result in property damage. Make sure that aluminum tubes do not come in direct contact or allow for condensate run-off with a dissimilar metal. Dissimilar metals can cause galvanic corrosion and possible premature failure.

Table 1 – Coil Connection Sizes

Model Size	Tonnage	Tube Size (in.)	
		Liquid	Suction
24	2	3/8	5/8
36	3	3/8	3/4
48	4	3/8	3/4

**! CAUTION**

**UNIT DAMAGE HAZARD**

Failure to follow this caution may result in product damage. To avoid valve damage to the refrigerant control device while brazing, wrap the valves wrap with a heat-sinking material such as a wet cloth.

Coil is provided with mechanical couplers for connecting the refrigerant tubes. Refer to Fig. 2 and follow these steps:

1. Loosen lock nut on coupler 1 turn. Do not remove lock nut.
2. Remove plug and check that O-ring is in place in the groove inside the coupler.
3. Cut refrigerant tubing to length and clean up the end square, smooth, and round.

**NOTE:** Burrs on tube end will cut and ruin the O-ring.

**NOTE:** See outdoor unit Installation Instructions regarding requirements for installation of a filter-drier in the liquid line close to the indoor coil.

4. Slide the refrigerant tube into the coupler until it bottoms out.
5. Hold the body of the coupler with one wrench and tighten the lock nut with another wrench. Tighten until the lock nut contacts the coupler hex flange.

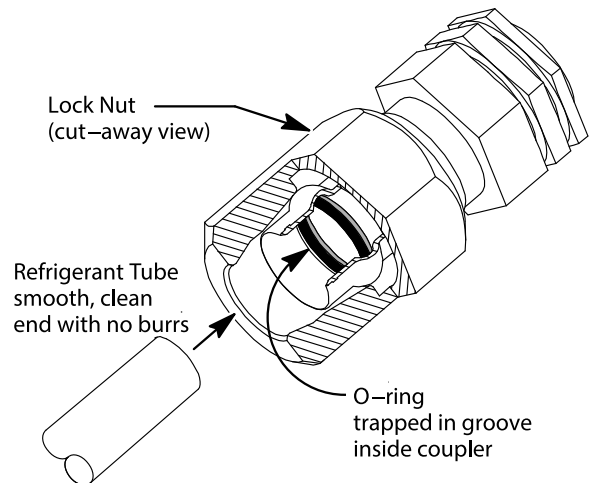

Fig. 2 – Refrigerant Line Mechanical Couplers

A240491

## Refrigerant Metering Device

These units have a factory installed hard shut-off TXV designed only for use with R-410A refrigerant. Use only with outdoor units designed for R-410A.

**NOTE:** ALL TXVS HAVE PRESET SUPERHEAT SETTINGS AND ARE FIELD NON-ADJUSTABLE.

Carefully remove TXV bulb insulation and verify that the TXV bulb is securely fastened with hose clamp. Tighten screw a half-turn past hand tight with TXV bulb placed in the indentation with full contact with the vapor line tube. Re-wrap TXV bulb with insulation.

## Condensate Drain Line Connection

### ! CAUTION

#### PROPERTY DAMAGE HAZARD

Failure to follow this caution may result in property damage. When installing over a finished ceiling and/or living area, install a field-fabricated secondary condensate pan under the entire unit.

The coil is designed to dispose of accumulated water through built-in condensate drain fittings. It is recommended that PVC fittings be used on the condensate pan. Do not over-tighten. Finger tighten plus 1½ turns. Be sure to install plastic plug in unused condensate drain fitting. There are two ¾" female threaded pipe in each coil condensate pan.

A trap is not necessary on the condensate line. Consult local codes for additional restrictions or precautions. If local codes require a trap then the following guidelines are suggested to assure proper drainage. Install a trap in condensate line of coil as close to the coil as possible. Make trap at least 3" (76 mm) deep and no higher than the bottom of unit condensate drain opening (Fig. 3). Pitch condensate line 1" (25.4 mm) for every 10 feet of length to an open drain or sump. Make sure that the outlet of each trap is below its connection to condensate pan to prevent condensate from overflowing the drain pan. Prime all traps, test for leaks, and insulate traps and lines if located above a living area.

**NOTE:** If unit is located in or above a living space, where damage may result from condensate overflow, a field-supplied, external condensate pan should be installed underneath the entire unit, and a secondary condensate line (with appropriate trap) should be run from the unit into the pan. Any condensate in this external condensate pan should be drained to a noticeable place. As an alternative to using an external condensate pan, some localities may allow the running of a separate 3/4" (19 mm) condensate line (with appropriate trap) per local code to a place where the condensate will be noticeable. The owner of the structure must be informed that when condensate flows from secondary drain or external condensate pan, the unit requires servicing or water damage will occur. To further protect against water damage, install a float switch to shut the unit off if the water in the secondary pan gets too high.

**NOTE:** To avoid drainage problems, test the primary drain line by slowly pouring water into the pan. Check piping for leaks and proper condensate drainage. Using the secondary drain as explained in the previous note provides further protection against overflow due to a clogged primary drain.

**NOTE:** In applications where return air humidity levels stay at 70% or above for a prolonged period of time, condensation can form on the bottom of pan and drip.

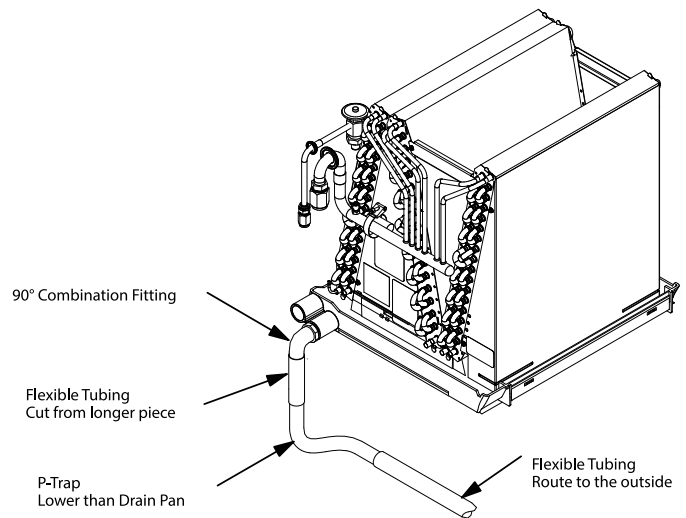

Fig. 3 – Condensate Drain

A05436

## Waste Line Connection

If the condensate line is to be connected to a waste (sewer) line, an open trap must be installed ahead of the waste line to prevent escape of sewer gases (Fig. 4).

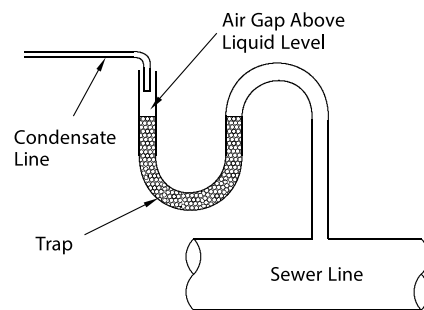

Fig. 4 – Condensate Drain to Waste Line

A10216

### ! WARNING

#### EXPLOSION HAZARD

Failure to follow this warning could result in personal injury or death. Provide the trap with an air gap in the drain line when connecting to a waste (sewer) line.

**NOTE:** The State of California requires Proposition 65 labels (Prop 65) for products containing materials of concern. Taped to the header plate is the Proposition 65 Label for this product. Apply this label on the outside front of the furnace coil casing.

## Check and Adjust Air Flow

### ! WARNING

#### ELECTRICAL SHOCK HAZARD

Failure to shut of electric power could result in personal injury or death. Before adjusting blower speed, shut off electric power to the furnace or blower module.

It is important that the correct amount of air (CFM) flows through the coil. The installer must determine the required CFM based on the characteristics of the specific system (such as system size, ducting,

components, and accessories). In general, 400 CFM per ton is the nominal required value, with a range of 350 – 450 CFM per ton.

**Check Static Pressure Drop and CFM Across Coil**

The amount of air (CFM) is related to a pressure drop. To determine the CFM, measure the pressure drop using an inclined manometer (sometimes called draft gauge or air flow gauge).

1. The coil should be dry and clean. The air filter must be clean and in place. All registers open. DO NOT run the outdoor unit when checking air flow.
2. Run the blower on cooling speed.
3. Using the manometer (draft gauge or flow gauge), measure the static pressure drop across the dry coil and compare it to the numbers in Table 1.
4. Find the corresponding CFM in Table 2.

**Table 2 – CFM and Pressure Drop**

Coil Size	CFM Across Coils	Static Pressure Drop Across Coil (inches Water Column)	
		Dry	Wet
24 (2 Ton)	700	0.182	0.214
	800	0.233	0.269
	900	0.290	0.336
36 (3 Ton)	1000	0.189	0.236
	1100	0.221	0.276
	1200	0.259	0.315
	1300	0.299	0.361
	1400	0.341	0.413
48 (4 Ton)	1400	0.322	0.348
	1500	0.366	0.396
	1600	0.413	0.446
	1700	*	*
	1800	*	*

\*. Excessive pressure drop; application not recommended

**Adjusting Air Flow**

If CFM is too low, increase the blower speed and measure the static pressure drop again. Determine CFM from Table 2.

If CFM is too high, reduce the blower speed and measure the static pressure drop again. Determine CFM from Table 2.

**NOTE:** Change blower speed as shown in the instructions for the furnace or air handler.

**NOTE:** It may not be possible to obtain a gauge reading exactly the same as shown in Table 2. This is due to variations in duct systems and blower speeds.

If the motor is at the highest speed and the CFM is still not high enough, replace the blower and/or motor with a larger size.

If the unit has an adjustable belt driven blower, use an ammeter to check the motor current draw. If the current draw is higher than the motor name plate amps, replace the motor with one of greater horsepower.

**START-UP PROCEDURE**

Refer to outdoor unit Installation Instructions for refrigeration system start-up instructions and refrigerant charging method details.

**NOTE:** The State of California requires Proposition 65 labels (Prop 65) for products containing materials of concern. Taped to the header plate is the Proposition 65 Label for this product. Apply this label on the outside front of the furnace coil casing.

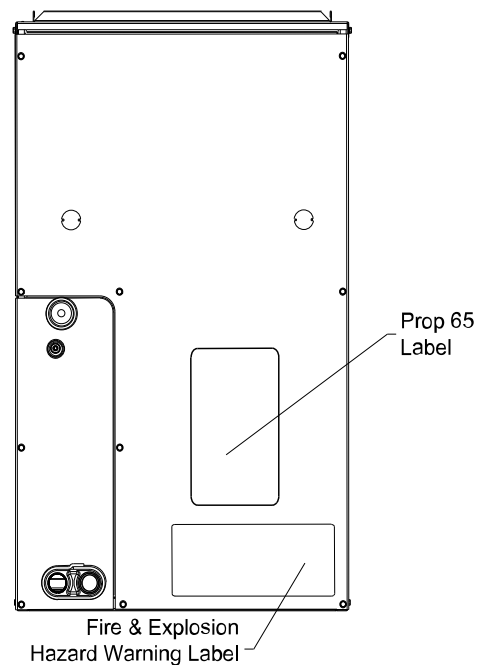

**Fig. 5 – Labels**

A180077

**NOTE:** Attached to the literature assembly is the Fire and Explosion Hazard warning label for this product. Apply this label on the outside front of the furnace coil casing if one does not exist on the casing. (Fig. 5)

! **CAUTION**

**ENVIRONMENTAL HAZARD**

Failure to follow this caution may result in environmental damage. Remove and recycle all components or materials (i.e., oil, refrigerant, etc.) before unit final disposal.