

Z1395XL YARD HYDRANT – Exposed Head, Non-Freeze

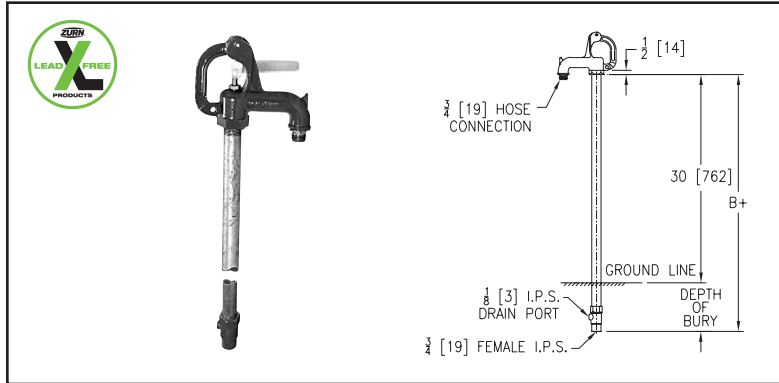

ENGINEERING SPECIFICATION: ZZURN Z1395XL Exposed, lead-free, non-freeze yard hydrant. Hydrant features a Dura-Coated cast iron head and lift handle with lock option, galvanized steel casing, bronze and stainless steel interior components, 3/4" [19] inlet connection with 1/8" [3] tapped drainage port on housing, and 3/4" [19] male hose connection.

Zurn "XL" Lead-Free compliant products are a line of durable plumbing products designed and manufactured to comply with state laws and local codes that mandate maximum allowable lead content levels. Zurn "XL" products are manufactured in accordance to the Federal SWDA section 1417.

Note: 'B' Dimension based on outlet connection 30" [762 mm] above ground.

**Non-freeze feature will not function when -VB suffix vacuum breaker is specified.

Z1395XL Yard Hydrant

The Z1395XL is an exposed head, non-freeze yard hydrant designed for garden areas, parks, farms, stables, and irrigational applications where immediate water flow, even in sub-zero degree temperatures, is necessary.

Hydrant Features

- **Certification** – City of LA listed.
- **Valve Seat** – Permanent bronze valve seat with conical seating surface.
- **Internal Components** – One-piece, replaceable, free-floating compression closure valve with neoprene plunger operates the water flow and drainage. Valve assembly is sealed with graphite-impregnated fiber packing and secured with a brass packing nut for leak resistance.
- **Casing** – Galvanized steel pipe.
- **Casing Guard** – Cast aluminum guard provides damage protection to the casing (optional).
- **Operating Handle** – Dura-Coated cast iron operating handle controls the valve assembly with the ability to be locked in a closed, tamper-proof position.
- **Operating Rod** – 3/8" [10 mm] solid brass.
- **Drainage** – Tapped, siphon-resistant drain port located in valve housing prevents sub-surface water contamination from entering the hydrant.
- **Depth of Bury** – Available from two (2) feet [610 mm] to eight (8) feet [2438 mm] in one (1)-foot increments.
- **Operating Pressures** – Minimum running pressure 8 psi. Maximum static pressure 125 psi.
- **Water Temperature Range** – Minimum 33°F. Maximum 130°F.

OPTIONS

SUFFIXES

- AC Aluminum Casing Guard
- RK Hydrant Parts Repair Kit
- VB 3/4" [19 mm] Adapter Vacuum Breaker**

Depth of Bury Feet [mm]	B+ Dimension Feet [mm]	Approx. Wt. Lbs. [Kg]
2 [610]	4-1/2 [1372]	15 [7]
3 [914]	5-1/2 [1676]	19 [9]
4 [1219]	6-1/2 [1981]	23 [10]
5 [1524]	7-1/2 [2286]	27 [12]
6 [1829]	8-1/2 [2591]	31 [14]
8 [2438]	10-1/2 [3200]	39 [18]

Z1395XL YARD HYDRANT Parts Assembly, Parts List, and Operating Rod Assemblies

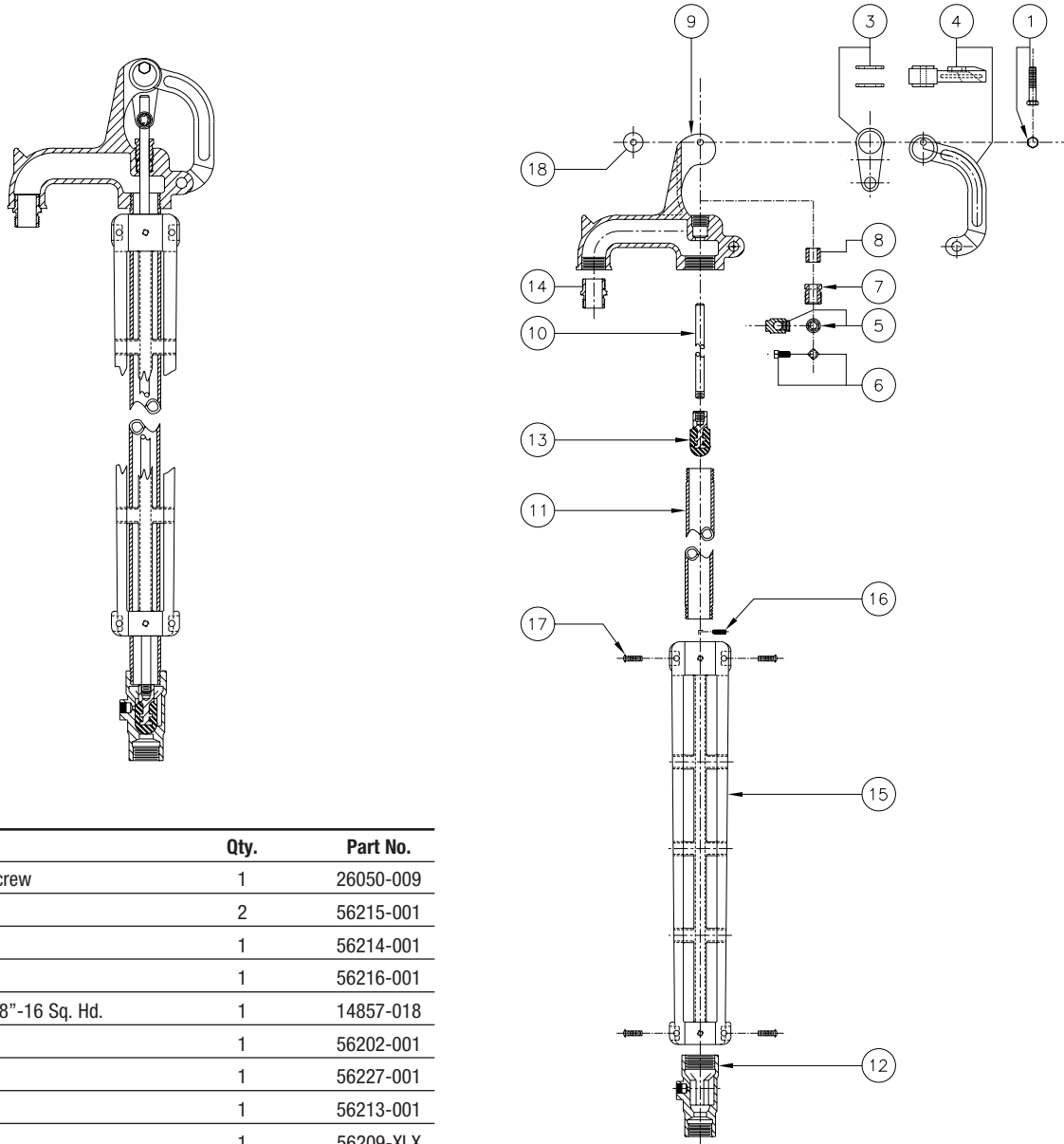

Z1395XL Parts List

Item	Description	Qty.	Part No.
*1	Handle Cap Screw	1	26050-009
3	Linkage	2	56215-001
4	Handle	1	56214-001
*5	Pivot Link	1	56216-001
*6	Setscrew – 3/8”-16 Sq. Hd.	1	14857-018
*7	Packing Nut	1	56202-001
*8	Packing	1	56227-001
9	Head	1	56213-001
10	Operating Rod	1	56209-XLX
11	Galvanized Casing	1	56217-XXX
12	Valve Housing	1	56224-XL1
*13	Plunger Assembly	1	56252-XL1
14	3/4” Hose Adapter	1	56222-XL1
15	Casing Guard (Optional)	2	31769-002
16	Casing Guard Setscrew (Optional)	2	18006-045
17	Screw #10-24 NC (Optional)	4	14853-046
*18	Push Nut	1	56467-001

Operating Rod Assemblies

2' Bury	57-1/2"
3' Bury	69-1/2"
4' Bury	81-1/2"
5' Bury	93-1/2"
6' Bury	105-1/2"
8' Bury	129-1/2"

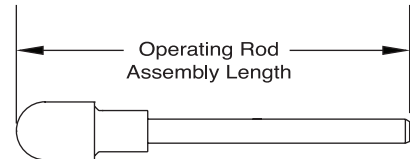

*Items are available in -RK Repair Kit Option bag (#66955-346-9).

Z1395XL YARD HYDRANT Troubleshooting Guide

PROBLEM	CAUSE	SOLUTION
Hydrant will not operate when turned on.	Water supply is shut off.	Turn on water supply.
Water is leaking around the operating rod and packing nut.	Operating rod has worn the packing.	Tighten the packing nut slowly until the leak stops.
	The packing nut cannot be tightened any more.	Follow steps 1-10 of the Service Guide.
Water does not shut off completely when hydrant is turned off.	Debris between seat and washer.	Follow steps 1, 11, and 13 of the Service Guide. Clean by turning water supply on and flush hydrant.
	Washer is worn out.	Follow steps 1 and 11-13 of the Service Guide.
Hydrant exhibits low flow.	Water supply to hydrant is restricted.	Check water supply to ensure that all upstream valves are fully open.

Z1395XL YARD HYDRANT Service Guide

Step 1: Shutting Off The Water Supply To The Hydrant

Locate the supply shut off valve and rotate until water supply is shut off.

If the packing was not the reason for service – skip to step 11.

Step 2: Removing the Handle and Adjacent Components

Lift the handle (4) just enough to relieve the tension and using a punch and hammer, punch the handle cap screw (1) through the push nut (18) and remove the handle cap screw (1) from the head (9). Rotate the handle downward and remove the loose linkage (3) piece and the handle (4).

Step 3: Removing the Pivot Linkage and Pivot Link

Mark the operating rod (10) at the top of the pivot link (5) for locating the pivot link (5) when reinstalling. Using a 3/8" open end wrench or crescent wrench and turning the setscrew (6) counterclockwise, remove the setscrew (6) and the pivot linkage (3) piece from the pivot link (5). Lift the pivot link (5) off the operating rod (10).

Step 4: Removing the Packing Nut

Using a 3/4" open end wrench or crescent wrench, turn the packing nut (7) counterclockwise until packing nut (7) is free from head (9). Lifting upward, remove from operating rod (10).

Step 5: Removing the Head

Using a magic marker, mark a vertical line on the hex portion of the head (9) and casing (11) as a guide when reinstalling the head (9). Using a pipe wrench and a large crescent wrench and turning the head (9) counterclockwise, remove the head (9) from the galvanized casing (11). Lift upward to remove the head (9) from operating rod (10).

Step 6: Replacing the Graphite Fiber Packing

Turn head (9) upside down and remove the packing (8). Use a flat punch and hammer and lightly tap packing (8) out of head (9). Turn the head (9) upright, and inserting new packing (8), lightly tap into place in head (9) without damaging the packing (8).

Step 7: Replacing the Packing Nut

By hand, screw the packing nut (7) into the head (9) finger tight only.

Step 8: Replacing the Head

Carefully slide the head (9) over the operating rod (10) up through the graphite fiber packing (8) and the packing nut (7). With pipe wrench and large crescent wrench, and turning clockwise, screw the head (9) tight until the lines on the casing (11) and the hex portion of the head (9) line up as before removing.

Step 9: Replacing the Pivot Link and Adjacent Linkage

Slide the pivot link (5) on to the operating rod (10) to the locating mark on the operating rod (10). Place one linkage (3) piece on to the side of the pivot link where the setscrew (6) goes, and using a 3/8" open end wrench or crescent wrench, turn the setscrew (6) clockwise until tight.

Step 10: Replacing the Handle and Adjacent Components

Place the handle (4) on the linkage (3) piece that is attached to the pivot link (5), then place the other linkage (3) piece on the handle (4) and on the pivot link (5), rotating upward into the head (9). Slide the handle cap screw (1) through the head (9) linkage (3) handle (4) linkage (3) head (9) and push on the push nut (18) until it touches the head (9).

Step 11: Removing Head Assembly and Operating Rod/Plunger Assembly

With a magic marker, mark a vertical line on the hex portion of the head (9) and the galvanized casing (11) as a guide when reinstalling the head (9). Lift the handle (4) all the way upward, and using a pipe wrench and large crescent wrench, turn the head (9) counterclockwise, unscrew the head (9) from the galvanized casing (11), and lift head (9) upward removing the operating rod (10) and plunger assembly (13) from galvanized casing (11).

Step 12: Replacing the Plunger Assembly

Turn the plunger assembly (13) counterclockwise and remove it from the operating rod (10). Place new plunger assembly (13) on operating rod (10), turn it clockwise and tighten.

Step 13: Replacing Head Assembly and Operating Rod/Plunger Assembly

Insert the plunger assembly (13) / operating rod (10) into the galvanized casing (11) until the head assembly (9) contacts the galvanized casing (11). Then using a pipe wrench and large crescent wrench and turning the head (9) clockwise, screw the head (9) tight until the lines on the galvanized casing (11) and the hex portion of the head (9) line up as before removing.

⚠ **WARNING:** Cancer and Reproductive Harm - www.P65Warnings.ca.gov
 ⚠ **ADVERTENCIA:** Cáncer y daño reproductivo - www.P65Warnings.ca.gov
 ⚠ **AVERTISSEMENT:** Cancer et effets néfastes sur la reproduction - www.P65Warnings.ca.gov

Z1395XL YARD HYDRANT 3/4" Hose Connection Chart and Graph

Z1395 Yard Hydrant – 3/4" Hose Connection				
Static Pressure (psi)	Running Inlet Pressure (psi)	Running Outlet Pressure (psi)	Flow Rate (gpm)	Pressure Drop Across Unit (psi)
10	5.4	0.2	5.8	5.2
20	13.3	2.1	9.0	11.2
30	21.7	4.0	11.4	17.6
40	30.5	6.3	13.5	24.3
50	39.0	8.4	15.3	30.6
60	45.7	10.2	16.6	35.6
70	58.1	13.3	18.7	44.8
80	65.8	15.5	19.9	50.4
90	72.8	17.5	20.9	55.3

